

Complete Machining Solutions

HOLE MAKING TOOLS



TABLE OF CONTENTS

INDEXABLE DRILLS	472	
SUMOCHAM.....	472	
COMBICHAM.....	488	
CHAMIQDRILL	505	
CHAMDRILL.....	511	
DR-TWIST	520	
DR-DH Semi-Standard Deep Drills	538	
CHAMFERING DRILLS	543	
MULTIFUNCTION TOOLS.....	550	
SOLID CARBIDE DRILLS.....	557	
DEEP HOLE DRILLING.....	598	
GUNDRILLS	648	
HIGH PRECISION REAMING.....	675	
TAPS	703	
ITS BORE.....	739	

INDEXABLE DRILLS





DCN A-1.5D

Indexable Head Drills with Coolant Holes and One Flat Shank, Drilling Depth 1.5xD

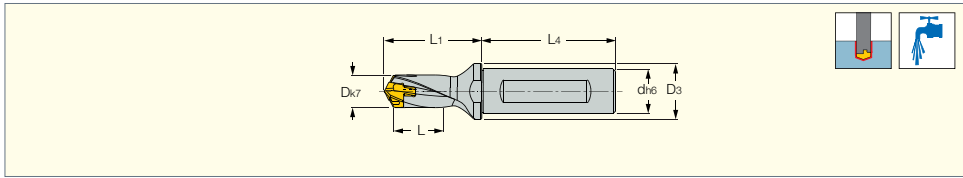

Designation	D _{min} ⁽¹⁾	D _{max}	L	d	D ₃	L ₁	L ₄	Po. Size	
DCN 060-009-12A-1.5D	6.00	6.40	9.0	12.00	16.00	23.0	45.0	6.0	K DCN 6-9.99-Y
DCN 065-010-12A-1.5D	6.50	6.90	10.0	12.00	16.00	24.1	45.0	6.5	K DCN 6-9.99-Y
DCN 070-011-12A-1.5D	7.00	7.40	11.0	12.00	16.00	25.1	45.0	7.0	K DCN 6-9.99
DCN 075-011-12A-1.5D	7.50	7.90	11.0	12.00	16.00	25.9	45.0	7.0	K DCN 6-9.99
DCN 080-012-12A-1.5D	8.00	8.40	12.0	12.00	16.00	27.9	45.0	8.0	K DCN 6-9.99
DCN 085-013-12A-1.5D	8.50	8.90	13.0	12.00	16.00	28.2	45.0	8.0	K DCN 6-9.99
DCN 090-014-12A-1.5D	9.00	9.40	14.0	12.00	16.00	29.3	45.0	9.0	K DCN 6-9.99
DCN 095-014-12A-1.5D	9.50	9.90	14.0	12.00	16.00	30.1	45.0	9.0	K DCN 6-9.99
DCN 100-015-16A-1.5D	10.00	10.40	15.0	16.00	20.00	31.2	48.0	10.0	K DCN 10-13.99
DCN 105-016-16A-1.5D	10.50	10.90	16.0	16.00	20.00	32.0	48.0	10.0	K DCN 10-13.99
DCN 110-017-16A-1.5D	11.00	11.40	17.0	16.00	20.00	33.1	48.0	11.0	K DCN 10-13.99
DCN 115-017-16A-1.5D	11.50	11.90	17.0	16.00	20.00	33.9	48.0	11.0	K DCN 10-13.99
DCN 120-018-16A-1.5D	12.00	12.40	18.0	16.00	20.00	35.0	48.0	12.0	K DCN 10-13.99
DCN 125-019-16A-1.5D	12.50	12.90	19.0	16.00	20.00	35.8	48.0	12.0	K DCN 10-13.99
DCN 130-020-16A-1.5D	13.00	13.40	20.0	16.00	20.00	37.1	48.0	13.0	K DCN 10-13.99
DCN 135-020-16A-1.5D	13.50	13.90	20.0	16.00	20.00	37.9	48.0	13.0	K DCN 10-13.99
DCN 140-021-16A-1.5D	14.00	14.40	21.0	16.00	20.00	41.1	48.0	14.0	K DCN 14-17.99
DCN 145-022-16A-1.5D	14.50	14.90	22.0	16.00	20.00	41.9	48.0	14.0	K DCN 14-17.99
DCN 150-023-20A-1.5D	15.00	15.90	23.0	20.00	25.00	46.2	50.0	15.0	K DCN 14-17.99
DCN 160-024-20A-1.5D	16.00	16.90	24.0	20.00	25.00	49.3	50.0	16.0	K DCN 14-17.99
DCN 170-026-20A-1.5D	17.00	17.90	26.0	20.00	25.00	52.4	50.0	17.0	K DCN 14-17.99
DCN 180-027-25A-1.5D	18.00	18.90	27.0	25.00	32.00	55.5	56.0	18.0	K DCN 18-21.99
DCN 190-029-25A-1.5D	19.00	19.90	29.0	25.00	32.00	58.5	56.0	19.0	K DCN 18-21.99
DCN 200-030-25A-1.5D	20.00	20.90	30.0	25.00	32.00	61.6	56.0	20.0	K DCN 18-21.99
DCN 210-032-25A-1.5D	21.00	21.90	32.0	25.00	32.00	64.7	56.0	21.0	K DCN 18-21.99
DCN 220-033-25A-1.5D	22.00	22.90	33.0	25.00	32.00	67.8	56.0	22.0	K DCN 22-26.99
DCN 230-035-32A-1.5D	23.00	23.90	35.0	32.00	42.00	70.9	60.0	23.0	K DCN 22-26.99
DCN 240-036-32A-1.5D	24.00	24.90	36.0	32.00	42.00	73.9	60.0	24.0	K DCN 22-26.99
DCN 250-038-32A-1.5D	25.00	25.90	38.0	32.00	42.00	77.0	60.0	25.0	K DCN 22-26.99
DCN 260-039-32A-1.5D	26.00	26.90	39.0	32.00	42.00	80.1	60.0	26.0	K DCN 22-26.99
DCN 270-041-32A-1.5D	27.00	27.90	41.0	32.00	42.00	83.1	60.0	27.0	K DCN 27-32.99
DCN 280-042-32A-1.5D	28.00	28.90	42.0	32.00	42.00	86.2	60.0	28.0	K DCN 27-32.99
DCN 290-044-32A-1.5D	29.00	29.90	44.0	32.00	42.00	89.3	60.0	29.0	K DCN 27-32.99
DCN 300-045-32A-1.5D	30.00	30.90	45.0	32.00	42.00	92.4	60.0	30.0	K DCN 27-32.99
DCN 310-047-32A-1.5D	31.00	31.90	47.0	32.00	42.00	95.5	60.0	31.0	K DCN 27-32.99
DCN 320-048-32A-1.5D	32.00	32.90	48.0	32.00	42.00	98.5	60.0	32.0	K DCN 27-32.99

• For user guide and cutting conditions, see pages 490

⁽¹⁾ Do not mount smaller drilling heads other than the specified range of the drill body

For inserts, see pages: FCP (486) • HCP-IQ (483) • ICK (484) • ICK-2M (485) • ICM (484) • ICP (484) • ICP-2M (485) • ICG (487)



DCN A-3D

Indexable Head Drills with
Coolant Holes and One Flat
Shank, Drilling Depth 3xD

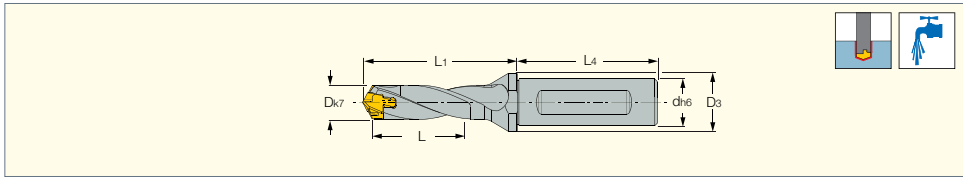

Designation	D _{min} ⁽¹⁾	D _{max}	L	d	D ₃	L ₁	L ₄	Po. Size	
DCN 060-018-12A-3D	6.00	6.40	18.0	12.00	16.00	32.0	45.0	6.0	K DCN 6-9.99-Y
DCN 065-020-12A-3D	6.50	6.90	20.0	12.00	16.00	33.8	45.0	6.5	K DCN 6-9.99-Y
DCN 070-021-12A-3D	7.00	7.40	21.0	12.00	16.00	35.6	45.0	7.0	K DCN 6-9.99
DCN 075-023-12A-3D	7.50	7.90	23.0	12.00	16.00	37.1	45.0	7.0	K DCN 6-9.99
DCN 080-024-12A-3D	8.00	8.40	24.0	12.00	16.00	39.4	45.0	8.0	K DCN 6-9.99
DCN 085-025-12A-3D	8.50	8.90	25.0	12.00	16.00	40.9	45.0	8.0	K DCN 6-9.99
DCN 090-027-12A-3D	9.00	9.40	27.0	12.00	16.00	42.8	45.0	9.0	K DCN 6-9.99
DCN 095-029-12A-3D	9.50	9.90	29.0	12.00	16.00	44.3	45.0	9.0	K DCN 6-9.99
DCN 100-030-16A-3D	10.00	10.40	30.0	16.00	20.00	46.2	48.0	10.0	K DCN 10-13.99
DCN 105-032-16A-3D	10.50	10.90	32.0	16.00	20.00	47.7	48.0	10.0	K DCN 10-13.99
DCN 110-033-16A-3D	11.00	11.40	33.0	16.00	20.00	49.6	48.0	11.0	K DCN 10-13.99
DCN 115-035-16A-3D	11.50	11.90	35.0	16.00	20.00	51.1	48.0	11.0	K DCN 10-13.99
DCN 120-036-16A-3D	12.00	12.40	36.0	16.00	20.00	53.0	48.0	12.0	K DCN 10-13.99
DCN 125-037-16A-3D	12.50	12.90	37.0	16.00	20.00	54.5	48.0	12.0	K DCN 10-13.99
DCN 130-039-16A-3D	13.00	13.40	39.0	16.00	20.00	56.6	48.0	13.0	K DCN 10-13.99
DCN 135-041-16A-3D	13.50	13.90	41.0	16.00	20.00	58.1	48.0	13.0	K DCN 10-13.99
DCN 140-042-16A-3D	14.00	14.40	42.0	16.00	20.00	62.1	48.0	14.0	K DCN 14-17.99
DCN 145-044-16A-3D	14.50	14.90	44.0	16.00	20.00	63.6	48.0	14.0	K DCN 14-17.99
DCN 150-045-20A-3D	15.00	15.90	45.0	20.00	25.00	68.7	50.0	15.0	K DCN 14-17.99
DCN 160-048-20A-3D	16.00	16.90	48.0	20.00	25.00	73.3	50.0	16.0	K DCN 14-17.99
DCN 170-051-20A-3D	17.00	17.90	51.0	20.00	25.00	77.9	50.0	17.0	K DCN 14-17.99
DCN 180-054-25A-3D	18.00	18.90	54.0	25.00	32.00	82.5	56.0	18.0	K DCN 18-21.99
DCN 190-057-25A-3D	19.00	19.90	57.0	25.00	32.00	87.0	56.0	19.0	K DCN 18-21.99
DCN 200-060-25A-3D	20.00	20.90	60.0	25.00	32.00	91.6	56.0	20.0	K DCN 18-21.99
DCN 210-063-25A-3D	21.00	21.90	63.0	25.00	32.00	96.2	56.0	21.0	K DCN 18-21.99
DCN 220-066-25A-3D	22.00	22.90	66.0	25.00	32.00	100.8	56.0	22.0	K DCN 22-26.99
DCN 230-069-32A-3D	23.00	23.90	69.0	32.00	42.00	105.4	60.0	23.0	K DCN 22-26.99
DCN 240-072-32A-3D	24.00	24.90	72.0	32.00	42.00	110.0	60.0	24.0	K DCN 22-26.99
DCN 250-075-32A-3D	25.00	25.90	75.0	32.00	42.00	114.5	60.0	25.0	K DCN 22-26.99
DCN 260-078-32A-3D	26.00	26.90	78.0	32.00	42.00	119.0	60.0	26.0	K DCN 22-26.99
DCN 270-081-32A-3D	27.00	27.90	81.0	32.00	42.00	123.7	60.0	27.0	K DCN 27-32.99
DCN 280-084-32A-3D	28.00	28.90	84.0	32.00	42.00	128.2	60.0	28.0	K DCN 27-32.99
DCN 290-087-32A-3D	29.00	29.90	87.0	32.00	42.00	132.8	60.0	29.0	K DCN 27-32.99
DCN 300-090-32A-3D	30.00	30.90	90.0	32.00	42.00	137.4	60.0	30.0	K DCN 27-32.99
DCN 310-093-32A-3D	31.00	31.90	93.0	32.00	42.00	142.0	60.0	31.0	K DCN 27-32.99
DCN 320-096-32A-3D	32.00	32.90	96.0	32.00	42.00	146.5	60.0	32.0	K DCN 27-32.99

• For user guide and cutting conditions, see pages 490

⁽¹⁾ Do not mount smaller drilling heads other than the specified range of the drill body

For inserts, see pages: HCP-IQ (483) • ICP (484) • ICM (484) • ICK (484) • ICP-2M (485) • ICK-2M (485) • FCP (486) • ICG (487)



DCN R-3D

Indexable Head Drills with Coolant Holes and a Cylindrical Shank, Drilling Depth 3xD

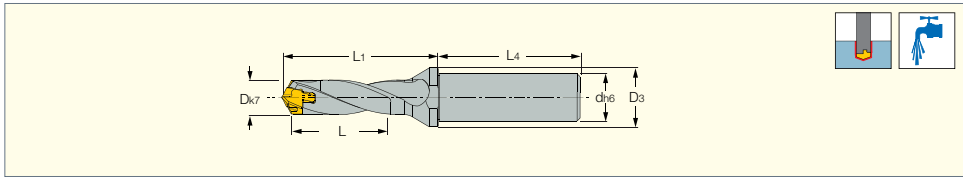

Designation	D _{min} ⁽¹⁾	D _{max}	L	d	D ₃	L ₁	L ₄	Po. Size	
DCN 060-018-12R-3D	6.00	6.40	18.0	12.00	16.00	32.0	45.0	6.0	K DCN 6-9.99-Y
DCN 065-020-12R-3D	6.50	6.90	20.0	12.00	16.00	33.8	45.0	6.5	K DCN 6-9.99-Y
DCN 070-021-12R-3D	7.00	7.40	21.0	12.00	16.00	35.6	45.0	7.0	K DCN 6-9.99
DCN 075-023-12R-3D	7.50	7.90	23.0	12.00	16.00	37.1	45.0	7.0	K DCN 6-9.99
DCN 080-024-12R-3D	8.00	8.40	24.0	12.00	16.00	39.4	45.0	8.0	K DCN 6-9.99
DCN 085-025-12R-3D	8.50	8.90	25.0	12.00	16.00	40.9	45.0	8.0	K DCN 6-9.99
DCN 090-027-12R-3D	9.00	9.40	27.0	12.00	16.00	42.8	45.0	9.0	K DCN 6-9.99
DCN 095-029-12R-3D	9.50	9.90	29.0	12.00	16.00	44.3	45.0	9.0	K DCN 6-9.99
DCN 100-030-16R-3D	10.00	10.40	30.0	16.00	20.00	46.2	48.0	10.0	K DCN 10-13.99
DCN 105-032-16R-3D	10.50	10.90	32.0	16.00	20.00	47.7	48.0	10.0	K DCN 10-13.99
DCN 110-033-16R-3D	11.00	11.40	33.0	16.00	20.00	49.6	48.0	11.0	K DCN 10-13.99
DCN 115-035-16R-3D	11.50	11.90	35.0	16.00	20.00	51.1	48.0	11.0	K DCN 10-13.99
DCN 120-036-16R-3D	12.00	12.40	36.0	16.00	20.00	53.0	48.0	12.0	K DCN 10-13.99
DCN 125-037-16R-3D	12.50	12.90	37.0	16.00	20.00	54.5	48.0	12.0	K DCN 10-13.99
DCN 130-039-16R-3D	13.00	13.40	39.0	16.00	20.00	56.6	48.0	13.0	K DCN 10-13.99
DCN 135-041-16R-3D	13.50	13.90	41.0	16.00	20.00	58.1	48.0	13.0	K DCN 10-13.99
DCN 140-042-16R-3D	14.00	14.40	42.0	16.00	20.00	62.1	48.0	14.0	K DCN 14-17.99
DCN 145-044-16R-3D	14.50	14.90	44.0	16.00	20.00	63.6	48.0	14.0	K DCN 14-17.99
DCN 150-045-20R-3D	15.00	15.90	45.0	20.00	25.00	68.7	50.0	15.0	K DCN 14-17.99
DCN 160-048-20R-3D	16.00	16.90	48.0	20.00	25.00	73.3	50.0	16.0	K DCN 14-17.99
DCN 170-051-20R-3D	17.00	17.90	51.0	20.00	25.00	77.9	50.0	17.0	K DCN 14-17.99
DCN 180-054-25R-3D	18.00	18.90	54.0	25.00	32.00	82.5	56.0	18.0	K DCN 18-21.99
DCN 190-057-25R-3D	19.00	19.90	57.0	25.00	32.00	87.0	56.0	19.0	K DCN 18-21.99
DCN 200-060-25R-3D	20.00	20.90	60.0	25.00	32.00	91.6	56.0	20.0	K DCN 18-21.99
DCN 210-063-25R-3D	21.00	21.90	63.0	25.00	32.00	96.2	56.0	21.0	K DCN 18-21.99
DCN 220-066-25R-3D	22.00	22.90	66.0	25.00	32.00	100.8	56.0	22.0	K DCN 22-26.99
DCN 230-069-32R-3D	23.00	23.90	69.0	32.00	42.00	105.4	60.0	23.0	K DCN 22-26.99
DCN 240-072-32R-3D	24.00	24.90	72.0	32.00	42.00	110.0	60.0	24.0	K DCN 22-26.99
DCN 250-075-32R-3D	25.00	25.90	75.0	32.00	42.00	114.5	60.0	25.0	K DCN 22-26.99
DCN 260-078-32R-3D	26.00	26.90	78.0	32.00	42.00	119.0	60.0	26.0	K DCN 22-26.99
DCN 270-081-32R-3D	27.00	27.90	81.0	32.00	42.00	123.7	60.0	27.0	K DCN 27-32.99
DCN 280-084-32R-3D	28.00	28.90	84.0	32.00	42.00	128.2	60.0	28.0	K DCN 27-32.99
DCN 290-087-32R-3D	29.00	29.90	87.0	32.00	42.00	132.8	60.0	29.0	K DCN 27-32.99
DCN 300-090-32R-3D	30.00	30.90	90.0	32.00	42.00	137.4	60.0	30.0	K DCN 27-32.99
DCN 310-093-32R-3D	31.00	31.90	93.0	32.00	42.00	142.0	60.0	31.0	K DCN 27-32.99
DCN 320-096-32R-3D	32.00	32.90	96.0	32.00	42.00	146.5	60.0	32.0	K DCN 27-32.99

• For user guide and cutting conditions, see pages 490

⁽¹⁾ Do not mount smaller drilling heads other than the specified range of the drill body

For inserts, see pages: FCP (486) • HCP-IQ (483) • ICK (484) • ICK-2M (485) • ICM (484) • ICP (484) • ICP-2M (485) • ICG (487)



SUMO^{UNI}CHAM

DCNS-3D

Indexable Head Drills without a Flange and One Flat Shank, Drilling Depth 3xD, Suitable for Chamfering Holders

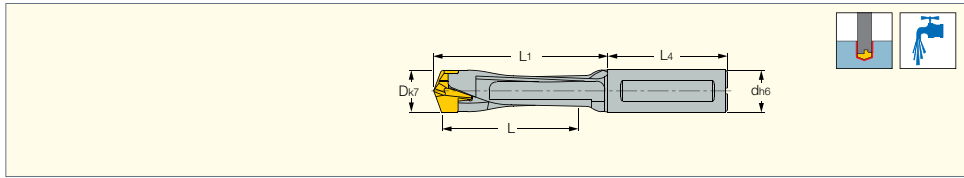

Designation	D _{min} ⁽¹⁾	D _{max}	L	d	L ₁	L ₄	Po. Size	
DCNS 075-022-080B-3D	7.50	7.90	22.5	8.00	34.2	36.0	7.0	K DCN 6-9.99
DCNS 080-024-080B-3D	8.00	8.40	24.0	8.00	34.7	36.0	8.0	K DCN 6-9.99
DCNS 085-025-090B-3D	8.50	8.90	25.5	9.00	36.9	36.0	8.0	K DCN 6-9.99
DCNS 090-027-090B-3D	9.00	9.40	27.0	9.00	38.8	36.0	9.0	K DCN 6-9.99
DCNS 095-029-100B-3D	9.50	9.90	28.5	10.00	40.3	36.0	9.0	K DCN 6-9.99
DCNS 100-030-100B-3D	10.00	10.40	30.0	10.00	45.2	41.0	10.0	K DCN 10-13.99
DCNS 105-032-110B-3D	10.50	10.90	31.5	11.00	46.7	41.0	10.0	K DCN 10-13.99
DCNS 110-033-110B-3D	11.00	11.40	33.0	11.00	48.6	41.0	11.0	K DCN 10-13.99
DCNS 115-035-120B-3D	11.50	11.90	34.5	12.00	50.1	41.0	11.0	K DCN 10-13.99
DCNS 120-036-120B-3D	12.00	12.40	36.0	12.00	52.0	41.0	12.0	K DCN 10-13.99
DCNS 125-037-130B-3D	12.50	12.90	37.5	13.00	53.5	46.0	12.0	K DCN 10-13.99
DCNS 130-039-130B-3D	13.00	13.40	39.0	13.00	55.6	47.0	13.0	K DCN 10-13.99
DCNS 135-041-140B-3D	13.50	13.90	40.5	14.00	57.1	43.0	13.0	K DCN 10-13.99
DCNS 140-042-140B-3D	14.00	14.40	42.0	14.00	59.2	44.0	14.0	K DCN 14-17.99
DCNS 145-044-150B-3D	14.50	14.90	43.5	15.00	60.7	45.0	14.0	K DCN 14-17.99
DCNS 150-045-150B-3D	15.00	15.90	45.0	15.00	62.7	45.0	15.0	K DCN 14-17.99
DCNS 160-048-160B-3D	16.00	16.90	48.0	16.00	69.7	48.0	16.0	K DCN 14-17.99
DCNS 170-051-170B-3D	17.00	17.90	51.0	17.00	71.9	48.0	17.0	K DCN 14-17.99
DCNS 180-054-180B-3D	18.00	18.90	54.0	18.00	75.5	48.0	18.0	K DCN 18-21.99
DCNS 190-057-190B-3D	19.00	19.90	57.0	19.00	78.6	54.0	19.0	K DCN 18-21.99
DCNS 200-060-200B-3D	20.00	20.90	60.0	20.00	88.1	54.0	20.0	K DCN 18-21.99
DCNS 210-063-210B-3D	21.00	21.90	63.0	21.00	90.7	60.0	21.0	K DCN 18-21.99
DCNS 220-066-220B-3D	22.00	22.90	66.0	22.00	94.3	60.0	22.0	K DCN 22-26.99
DCNS 230-069-230B-3D	23.00	23.90	69.0	23.00	97.8	60.0	23.0	K DCN 22-26.99
DCNS 240-072-240B-3D	24.00	24.90	72.0	24.00	101.4	60.0	24.0	K DCN 22-26.99
DCNS 250-075-250B-3D	25.00	25.90	75.0	25.00	105.0	60.0	25.0	K DCN 22-26.99

• For user guide and cutting conditions, see pages 490

⁽¹⁾ Do not mount smaller drilling heads other than the specified range of the drill body

For inserts, see pages: FCP (486) • HCP-IQ (483) • ICK (484) • ICK-2M (485) • ICM (484) • ICP (484) • ICP-2M (485) • ICG (487)



DCNS-5D

Indexable Head Drills without a Flange and One Flat Shank, Drilling Depth 5xD, Suitable for Chamfering Holders

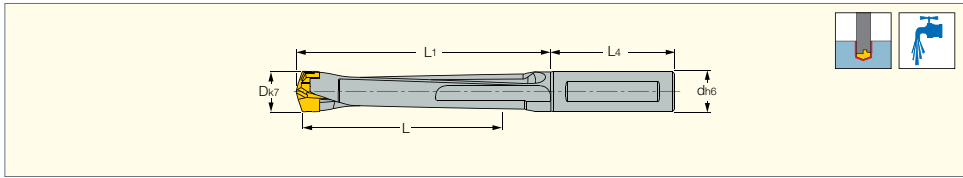

Designation	D _{min} ⁽¹⁾	D _{max}	L	d	L ₁	L ₄	Po. Size	
DCNS 075-037-080B-5D	7.50	7.90	37.5	8.00	49.2	36.0	7.0	K DCN 6-9.99
DCNS 080-040-080B-5D	8.00	8.40	40.0	8.00	56.4	36.0	8.0	K DCN 6-9.99
DCNS 085-042-090B-5D	8.50	8.90	42.5	9.00	53.9	36.0	8.0	K DCN 6-9.99
DCNS 090-045-090B-5D	9.00	9.40	45.0	9.00	56.8	36.0	9.0	K DCN 6-9.99
DCNS 095-048-100B-5D	9.50	9.90	47.5	10.00	59.3	36.0	9.0	K DCN 6-9.99
DCNS 100-050-100B-5D	10.00	10.40	50.0	10.00	65.2	41.0	10.0	K DCN 10-13.99
DCNS 105-053-110B-5D	10.50	10.90	52.5	11.00	67.7	41.0	10.0	K DCN 10-13.99
DCNS 110-055-110B-5D	11.00	11.40	55.0	11.00	70.6	41.0	11.0	K DCN 10-13.99
DCNS 115-058-120B-5D	11.50	11.90	57.5	12.00	73.1	41.0	11.0	K DCN 10-13.99
DCNS 120-060-120B-5D	12.00	12.40	60.0	12.00	76.0	41.0	12.0	K DCN 10-13.99
DCNS 125-062-130B-5D	12.50	12.90	62.5	13.00	78.5	46.0	12.0	K DCN 10-13.99
DCNS 130-065-130B-5D	13.00	13.40	65.0	13.00	81.6	47.0	13.0	K DCN 10-13.99
DCNS 135-068-140B-5D	13.50	13.90	67.5	14.00	84.1	43.0	13.0	K DCN 10-13.99
DCNS 140-070-140B-5D	14.00	14.40	70.0	14.00	87.2	44.0	14.0	K DCN 14-17.99
DCNS 145-073-150B-5D	14.50	14.90	72.5	15.00	89.7	45.0	14.0	K DCN 14-17.99
DCNS 150-075-150B-5D	15.00	15.90	75.0	15.00	92.7	45.0	15.0	K DCN 14-17.99
DCNS 160-080-160B-5D	16.00	16.90	80.0	16.00	101.7	48.0	16.0	K DCN 14-17.99
DCNS 170-085-170B-5D	17.00	17.90	85.0	17.00	105.9	48.0	17.0	K DCN 14-17.99
DCNS 180-090-180B-5D	18.00	18.90	90.0	18.00	111.5	48.0	18.0	K DCN 18-21.99
DCNS 190-095-190B-5D	19.00	19.90	95.0	19.00	116.6	54.0	19.0	K DCN 18-21.99
DCNS 200-100-200B-5D	20.00	20.90	100.0	20.00	128.1	54.0	20.0	K DCN 18-21.99
DCNS 210-105-210B-5D	21.00	21.90	105.0	21.00	132.7	60.0	21.0	K DCN 18-21.99
DCNS 220-110-220B-5D	22.00	22.90	110.0	22.00	138.3	60.0	22.0	K DCN 22-26.99
DCNS 230-115-230B-5D	23.00	23.90	115.0	23.00	143.8	60.0	23.0	K DCN 22-26.99
DCNS 240-120-240B-5D	24.00	24.90	120.0	24.00	149.4	60.0	24.0	K DCN 22-26.99
DCNS 250-125-250B-5D	25.00	25.90	125.0	25.00	155.0	60.0	25.0	K DCN 22-26.99

• For user guide and cutting conditions, see pages 490

⁽¹⁾ Do not mount smaller drilling heads other than the specified range of the drill body

For inserts, see pages: FCP (486) • HCP-IQ (483) • ICK (484) • ICK-2M (485) • ICM (484) • ICP (484) • ICP-2M (485) • ICG (487)



DCN A-5D

Indexable Head Drills with
Coolant Holes and One Flat
Shank, Drilling Depth 5xD

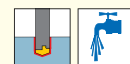
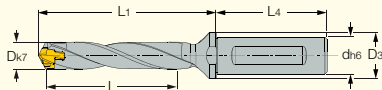

Designation	D _{min} ⁽¹⁾	D _{max}	L	d	D ₃	L ₁	L ₄	Po. Size	
DCN 060-030-12A-5D	6.00	6.40	30.0	12.00	16.00	44.0	45.0	6.0	K DCN 6-9.99-Y
DCN 065-033-12A-5D	6.50	6.90	33.0	12.00	16.00	46.8	45.0	6.5	K DCN 6-9.99-Y
DCN 070-035-12A-5D	7.00	7.40	35.0	12.00	16.00	49.6	45.0	7.0	K DCN 6-9.99
DCN 075-038-12A-5D	7.50	7.90	38.0	12.00	16.00	52.1	45.0	7.0	K DCN 6-9.99
DCN 080-040-12A-5D	8.00	8.40	40.0	12.00	16.00	55.4	45.0	8.0	K DCN 6-9.99
DCN 085-042-12A-5D	8.50	8.90	42.5	12.00	16.00	57.9	45.0	8.0	K DCN 6-9.99
DCN 090-045-12A-5D	9.00	9.40	45.0	12.00	16.00	60.8	45.0	9.0	K DCN 6-9.99
DCN 095-048-12A-5D	9.50	9.90	48.0	12.00	16.00	63.3	45.0	9.0	K DCN 6-9.99
DCN 100-050-16A-5D	10.00	10.40	50.0	16.00	20.00	66.2	48.0	10.0	K DCN 10-13.99
DCN 105-053-16A-5D	10.50	10.90	53.0	16.00	20.00	68.7	48.0	10.0	K DCN 10-13.99
DCN 110-055-16A-5D	11.00	11.40	55.0	16.00	20.00	71.6	48.0	11.0	K DCN 10-13.99
DCN 115-058-16A-5D	11.50	11.90	58.0	16.00	20.00	74.1	48.0	11.0	K DCN 10-13.99
DCN 120-060-16A-5D	12.00	12.40	60.0	16.00	20.00	77.0	48.0	12.0	K DCN 10-13.99
DCN 125-062-16A-5D	12.50	12.90	62.0	16.00	20.00	79.5	48.0	12.0	K DCN 10-13.99
DCN 130-065-16A-5D	13.00	13.40	65.0	16.00	20.00	82.6	48.0	13.0	K DCN 10-13.99
DCN 135-068-16A-5D	13.50	13.90	68.0	16.00	20.00	85.1	48.0	13.0	K DCN 10-13.99
DCN 140-070-16A-5D	14.00	14.40	70.0	16.00	20.00	90.2	48.0	14.0	K DCN 14-17.99
DCN 145-073-16A-5D	14.50	14.90	73.0	16.00	20.00	92.7	48.0	14.0	K DCN 14-17.99
DCN 150-075-20A-5D	15.00	15.90	75.0	20.00	25.00	98.7	50.0	15.0	K DCN 14-17.99
DCN 160-080-20A-5D	16.00	16.90	80.0	20.00	25.00	105.3	50.0	16.0	K DCN 14-17.99
DCN 170-085-20A-5D	17.00	17.90	85.0	20.00	25.00	111.9	50.0	17.0	K DCN 14-17.99
DCN 180-090-25A-5D	18.00	18.90	90.0	25.00	32.00	118.5	56.0	18.0	K DCN 18-21.99
DCN 190-095-25A-5D	19.00	19.90	95.0	25.00	32.00	125.0	56.0	19.0	K DCN 18-21.99
DCN 200-100-25A-5D	20.00	20.90	100.0	25.00	32.00	131.6	56.0	20.0	K DCN 18-21.99
DCN 210-105-25A-5D	21.00	21.90	105.0	25.00	32.00	138.2	56.0	21.0	K DCN 18-21.99
DCN 220-110-25A-5D	22.00	22.90	110.0	25.00	32.00	144.8	56.0	22.0	K DCN 22-26.99
DCN 230-115-32A-5D	23.00	23.90	115.0	32.00	42.00	151.4	60.0	23.0	K DCN 22-26.99
DCN 240-120-32A-5D	24.00	24.90	120.0	32.00	42.00	158.0	60.0	24.0	K DCN 22-26.99
DCN 250-125-32A-5D	25.00	25.90	125.0	32.00	42.00	164.5	60.0	25.0	K DCN 22-26.99
DCN 260-130-32A-5D	26.00	26.90	130.0	32.00	42.00	171.0	60.0	26.0	K DCN 22-26.99
DCN 270-135-32A-5D	27.00	27.90	135.0	32.00	42.00	177.7	60.0	27.0	K DCN 27-32.99
DCN 280-140-32A-5D	28.00	28.90	140.0	32.00	42.00	184.2	60.0	28.0	K DCN 27-32.99
DCN 290-145-32A-5D	29.00	29.90	145.0	32.00	42.00	190.8	60.0	29.0	K DCN 27-32.99
DCN 300-150-32A-5D	30.00	30.90	150.0	32.00	42.00	197.4	60.0	30.0	K DCN 27-32.99
DCN 310-155-32A-5D	31.00	31.90	155.0	32.00	42.00	204.0	60.0	31.0	K DCN 27-32.99
DCN 320-160-32A-5D	32.00	32.90	160.0	32.00	42.00	210.5	60.0	32.0	K DCN 27-32.99

• For user guide and cutting conditions, see pages 490

⁽¹⁾ Do not mount smaller drilling heads other than the specified range of the drill body

For inserts, see pages: FCP (486) • HCP-IQ (483) • ICK (484) • ICK-2M (485) • ICM (484) • ICP (484) • ICP-2M (485) • ICG (487)



DCN R-5D

Indexable Head Drills with
Coolant Holes and Cylindrical
Shanks, Drilling Depth 5xD

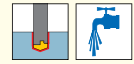
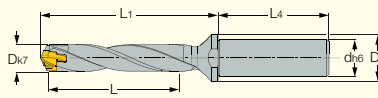

Designation	D _{min} ⁽¹⁾	D _{max}	L	d	D ₃	L ₁	L ₄	Po. Size	
DCN 060-030-12R-5D	6.00	6.40	30.0	12.00	16.00	44.0	45.0	6.0	K DCN 6-9.99-Y
DCN 065-033-12R-5D	6.50	6.90	33.0	12.00	16.00	46.8	45.0	6.5	K DCN 6-9.99-Y
DCN 070-035-12R-5D	7.00	7.40	35.0	12.00	16.00	49.6	45.0	7.0	K DCN 6-9.99
DCN 075-038-12R-5D	7.50	7.90	38.0	12.00	16.00	52.1	45.0	7.0	K DCN 6-9.99
DCN 080-040-12R-5D	8.00	8.40	40.0	12.00	16.00	55.4	45.0	8.0	K DCN 6-9.99
DCN 085-042-12R-5D	8.50	8.90	42.0	12.00	16.00	57.9	45.0	8.0	K DCN 6-9.99
DCN 090-045-12R-5D	9.00	9.40	45.0	12.00	16.00	60.8	45.0	9.0	K DCN 6-9.99
DCN 095-048-12R-5D	9.50	9.90	48.0	12.00	16.00	63.3	45.0	9.0	K DCN 6-9.99
DCN 100-050-16R-5D	10.00	10.40	50.0	16.00	20.00	66.2	48.0	10.0	K DCN 10-13.99
DCN 105-053-16R-5D	10.50	10.90	53.0	16.00	20.00	68.7	48.0	10.0	K DCN 10-13.99
DCN 110-055-16R-5D	11.00	11.40	55.0	16.00	20.00	71.6	48.0	11.0	K DCN 10-13.99
DCN 115-058-16R-5D	11.50	11.90	58.0	16.00	20.00	74.1	48.0	11.0	K DCN 10-13.99
DCN 120-060-16R-5D	12.00	12.40	60.0	16.00	20.00	77.0	48.0	12.0	K DCN 10-13.99
DCN 125-062-16R-5D	12.50	12.90	62.0	16.00	20.00	79.5	48.0	12.0	K DCN 10-13.99
DCN 130-065-16R-5D	13.00	13.40	65.0	16.00	20.00	82.6	48.0	13.0	K DCN 10-13.99
DCN 135-068-16R-5D	13.50	13.90	68.0	16.00	20.00	85.1	48.0	13.0	K DCN 10-13.99
DCN 140-070-16R-5D	14.00	14.40	70.0	16.00	20.00	90.2	48.0	14.0	K DCN 14-17.99
DCN 145-073-16R-5D	14.50	14.90	73.0	16.00	20.00	92.7	48.0	14.0	K DCN 14-17.99
DCN 150-075-20R-5D	15.00	15.90	75.0	20.00	25.00	98.7	50.0	15.0	K DCN 14-17.99
DCN 160-080-20R-5D	16.00	16.90	80.0	20.00	25.00	105.3	50.0	16.0	K DCN 14-17.99
DCN 170-085-20R-5D	17.00	17.90	85.0	20.00	25.00	111.9	50.0	17.0	K DCN 14-17.99
DCN 180-090-25R-5D	18.00	18.90	90.0	25.00	32.00	118.5	56.0	18.0	K DCN 18-21.99
DCN 190-095-25R-5D	19.00	19.90	95.0	25.00	32.00	125.0	56.0	19.0	K DCN 18-21.99
DCN 200-100-25R-5D	20.00	20.90	100.0	25.00	32.00	131.6	56.0	20.0	K DCN 18-21.99
DCN 210-105-25R-5D	21.00	21.90	105.0	25.00	32.00	138.2	56.0	21.0	K DCN 18-21.99
DCN 220-110-25R-5D	22.00	22.90	110.0	25.00	32.00	144.8	56.0	22.0	K DCN 22-26.99
DCN 230-115-32R-5D	23.00	23.90	115.0	32.00	42.00	151.4	60.0	23.0	K DCN 22-26.99
DCN 240-120-32R-5D	24.00	24.90	120.0	32.00	42.00	158.0	60.0	24.0	K DCN 22-26.99
DCN 250-125-32R-5D	25.00	25.90	125.0	32.00	42.00	164.5	60.0	25.0	K DCN 22-26.99
DCN 260-130-32R-5D	26.00	26.90	130.0	32.00	42.00	171.0	60.0	26.0	K DCN 22-26.99
DCN 270-135-32R-5D	27.00	27.90	135.0	32.00	42.00	177.7	60.0	27.0	K DCN 27-32.99
DCN 280-140-32R-5D	28.00	28.90	140.0	32.00	42.00	184.2	60.0	28.0	K DCN 27-32.99
DCN 290-145-32R-5D	29.00	29.90	145.0	32.00	42.00	190.8	60.0	29.0	K DCN 27-32.99
DCN 300-150-32R-5D	30.00	30.90	150.0	32.00	42.00	197.4	60.0	30.0	K DCN 27-32.99
DCN 310-155-32R-5D	31.00	31.90	155.0	32.00	42.00	204.0	60.0	31.0	K DCN 27-32.99
DCN 320-160-32R-5D	32.00	32.90	160.0	32.00	42.00	210.5	60.0	32.0	K DCN 27-32.99

• For user guide and cutting conditions, see pages 490

⁽¹⁾ Do not mount smaller drilling heads other than the specified range of the drill body

For inserts, see pages: FCP (486) • HCP-IQ (483) • ICK (484) • ICK-2M (485) • ICM (484) • ICP (484) • ICP-2M (485) • ICG (487)





DCN A-8D

Indexable Head Drills with Coolant Holes and One Flat Shank, Drilling Depth 8xD

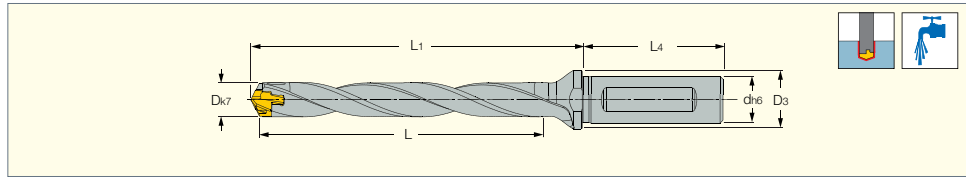

Designation	D _{min} ⁽¹⁾	D _{max}	L	d	D ₃	L ₁	L ₄	Po. Size	
DCN 060-048-12A-8D	6.00	6.40	48.0	12.00	16.00	62.0	45.0	6.0	K DCN 6-9.99-Y
DCN 065-052-12A-8D	6.50	6.90	52.0	12.00	16.00	66.3	45.0	6.5	K DCN 6-9.99-Y
DCN 070-056-12A-8D	7.00	7.40	56.0	12.00	16.00	70.6	45.0	7.0	K DCN 6-9.99
DCN 075-060-12A-8D	7.50	7.90	60.0	12.00	16.00	74.6	45.0	7.0	K DCN 6-9.99
DCN 080-064-12A-8D	8.00	8.40	64.0	12.00	16.00	79.4	45.0	8.0	K DCN 6-9.99
DCN 085-068-12A-8D	8.50	8.90	68.0	12.00	16.00	83.4	45.0	8.0	K DCN 6-9.99
DCN 090-072-12A-8D	9.00	9.40	72.0	12.00	16.00	87.8	45.0	9.0	K DCN 6-9.99
DCN 095-076-12A-8D	9.50	9.90	76.0	12.00	16.00	91.8	45.0	9.0	K DCN 6-9.99
DCN 100-080-16A-8D	10.00	10.40	80.0	16.00	20.00	96.2	48.0	10.0	K DCN 10-13.99
DCN 105-084-16A-8D	10.50	10.90	84.0	16.00	20.00	100.2	48.0	10.0	K DCN 10-13.99
DCN 110-088-16A-8D	11.00	11.40	88.0	16.00	20.00	104.6	48.0	11.0	K DCN 10-13.99
DCN 115-092-16A-8D	11.50	11.90	92.0	16.00	20.00	108.6	48.0	11.0	K DCN 10-13.99
DCN 120-096-16A-8D	12.00	12.40	96.0	16.00	20.00	113.0	48.0	12.0	K DCN 10-13.99
DCN 125-100-16A-8D	12.50	12.90	100.0	16.00	20.00	117.0	48.0	12.0	K DCN 10-13.99
DCN 130-104-16A-8D	13.00	13.40	104.0	16.00	20.00	121.6	48.0	13.0	K DCN 10-13.99
DCN 135-108-16A-8D	13.50	13.90	108.0	16.00	20.00	125.6	48.0	13.0	K DCN 10-13.99
DCN 140-112-16A-8D	14.00	14.40	112.0	16.00	20.00	132.1	48.0	14.0	K DCN 14-17.99
DCN 145-116-16A-8D	14.50	14.90	116.0	16.00	20.00	136.2	48.0	14.0	K DCN 14-17.99
DCN 150-120-20A-8D	15.00	15.90	120.0	20.00	25.00	143.7	50.0	15.0	K DCN 14-17.99
DCN 160-128-20A-8D	16.00	16.90	128.0	20.00	25.00	153.3	50.0	16.0	K DCN 14-17.99
DCN 170-136-20A-8D	17.00	17.90	136.0	20.00	25.00	162.9	50.0	17.0	K DCN 14-17.99
DCN 180-144-25A-8D	18.00	18.90	144.0	25.00	32.00	172.5	56.0	18.0	K DCN 18-21.99
DCN 190-152-25A-8D	19.00	19.90	152.0	25.00	32.00	182.0	56.0	19.0	K DCN 18-21.99
DCN 200-160-25A-8D	20.00	20.90	160.0	25.00	32.00	191.6	56.0	20.0	K DCN 18-21.99
DCN 210-168-25A-8D	21.00	21.90	168.0	25.00	32.00	201.2	56.0	21.0	K DCN 18-21.99
DCN 220-176-25A-8D	22.00	22.90	176.0	25.00	32.00	210.8	56.0	22.0	K DCN 22-26.99
DCN 230-184-32A-8D	23.00	23.90	184.0	32.00	42.00	220.4	60.0	23.0	K DCN 22-26.99
DCN 240-192-32A-8D	24.00	24.90	192.0	32.00	42.00	230.0	60.0	24.0	K DCN 22-26.99
DCN 250-200-32A-8D	25.00	25.90	200.0	32.00	42.00	239.5	60.0	25.0	K DCN 22-26.99
DCN 260-208-32A-8D	26.00	26.90	208.0	32.00	42.00	249.3	60.0	26.0	K DCN 22-26.99
DCN 270-216-32A-8D	27.00	27.90	216.0	32.00	42.00	258.6	60.0	27.0	K DCN 27-32.99
DCN 280-224-32A-8D	28.00	28.90	224.0	32.00	42.00	268.2	60.0	28.0	K DCN 27-32.99
DCN 290-232-32A-8D	29.00	29.90	232.0	32.00	42.00	277.8	60.0	29.0	K DCN 27-32.99
DCN 300-240-32A-8D	30.00	30.90	240.0	32.00	42.00	287.4	60.0	30.0	K DCN 27-32.99
DCN 310-248-32A-8D	31.00	31.90	248.0	32.00	42.00	297.0	60.0	31.0	K DCN 27-32.99
DCN 320-256-32A-8D	32.00	32.90	256.0	32.00	42.00	306.5	60.0	32.0	K DCN 27-32.99

• Prior to using the 8xD drill, it is recommended to drill a pre-hole by using a DCN 1.5xD drill or a centering drill. It is not required if HCP drilling head is used

• For user guide and cutting conditions, see pages 490

⁽¹⁾ Do not mount smaller drilling heads other than the specified range of the drill body

For inserts, see pages: FCP (486) • HCP-IQ (483) • ICK (484) • ICK-2M (485) • ICM (484) • ICP (484) • ICP-2M (485) • ICG (487)



DCN R-8D

Indexable Head Drills with
Coolant Holes and a Cylindrical
Shank, Drilling Depth 8xD

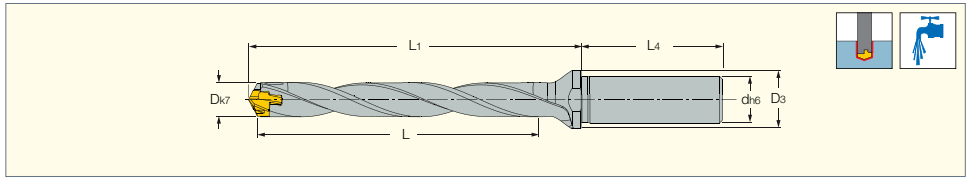

Designation	D _{min} ⁽¹⁾	D _{max}	L	d	D ₃	L ₁	L ₄	Po. Size	
DCN 060-048-12R-8D	6.00	6.40	48.0	12.00	16.00	62.0	45.0	6.0	K DCN 6-9.99-Y
DCN 065-052-12R-8D	6.50	6.90	52.0	12.00	16.00	66.3	45.0	6.5	K DCN 6-9.99-Y
DCN 070-056-12R-8D	7.00	7.40	56.0	12.00	16.00	70.6	45.0	7.0	K DCN 6-9.99
DCN 075-060-12R-8D	7.50	7.90	60.0	12.00	16.00	74.6	45.0	7.0	K DCN 6-9.99
DCN 080-064-12R-8D	8.00	8.40	64.0	12.00	16.00	79.4	45.0	8.0	K DCN 6-9.99
DCN 085-068-12R-8D	8.50	8.90	68.0	12.00	16.00	83.4	45.0	8.0	K DCN 6-9.99
DCN 090-072-12R-8D	9.00	9.40	72.0	12.00	16.00	87.8	45.0	9.0	K DCN 6-9.99
DCN 095-076-12R-8D	9.50	9.90	76.0	12.00	16.00	91.8	45.0	9.0	K DCN 6-9.99
DCN 100-080-16R-8D	10.00	10.40	80.0	16.00	20.00	96.2	48.0	10.0	K DCN 10-13.99
DCN 105-084-16R-8D	10.50	10.90	84.0	16.00	20.00	100.2	48.0	10.0	K DCN 10-13.99
DCN 110-088-16R-8D	11.00	11.40	88.0	16.00	20.00	104.6	48.0	11.0	K DCN 10-13.99
DCN 115-092-16R-8D	11.50	11.90	92.0	16.00	20.00	108.6	48.0	11.0	K DCN 10-13.99
DCN 120-096-16R-8D	12.00	12.40	96.0	16.00	20.00	113.0	48.0	12.0	K DCN 10-13.99
DCN 125-100-16R-8D	12.50	12.90	100.0	16.00	20.00	117.0	48.0	12.0	K DCN 10-13.99
DCN 130-104-16R-8D	13.00	13.40	104.0	16.00	20.00	121.6	48.0	13.0	K DCN 10-13.99
DCN 135-108-16R-8D	13.50	13.90	108.0	16.00	20.00	125.6	48.0	13.0	K DCN 10-13.99
DCN 140-112-16R-8D	14.00	14.40	112.0	16.00	20.00	132.1	48.0	14.0	K DCN 14-17.99
DCN 145-116-16R-8D	14.50	14.90	116.0	16.00	20.00	136.2	48.0	14.0	K DCN 14-17.99
DCN 150-120-20R-8D	15.00	15.90	120.0	20.00	25.00	143.7	50.0	15.0	K DCN 14-17.99
DCN 160-128-20R-8D	16.00	16.90	128.0	20.00	25.00	153.3	50.0	16.0	K DCN 14-17.99
DCN 170-136-20R-8D	17.00	17.90	136.0	20.00	25.00	162.9	50.0	17.0	K DCN 14-17.99
DCN 180-144-25R-8D	18.00	18.90	144.0	25.00	32.00	172.5	56.0	18.0	K DCN 18-21.99
DCN 190-152-25R-8D	19.00	19.90	152.0	25.00	32.00	182.0	56.0	19.0	K DCN 18-21.99
DCN 200-160-25R-8D	20.00	20.90	160.0	25.00	32.00	191.6	56.0	20.0	K DCN 18-21.99
DCN 210-168-25R-8D	21.00	21.90	168.0	25.00	32.00	201.2	56.0	21.0	K DCN 18-21.99
DCN 220-176-25R-8D	22.00	22.90	176.0	25.00	32.00	210.8	56.0	22.0	K DCN 22-26.99
DCN 230-184-32R-8D	23.00	23.90	184.0	32.00	42.00	220.4	60.0	23.0	K DCN 22-26.99
DCN 240-192-32R-8D	24.00	24.90	192.0	32.00	42.00	230.0	60.0	24.0	K DCN 22-26.99
DCN 250-200-32R-8D	25.00	25.90	200.0	32.00	42.00	239.5	60.0	25.0	K DCN 22-26.99
DCN 260-208-32R-8D	26.00	26.90	208.0	32.00	42.00	249.3	60.0	26.0	K DCN 22-26.99
DCN 270-216-32R-8D	27.00	27.90	216.0	32.00	42.00	258.6	60.0	27.0	K DCN 27-32.99
DCN 280-224-32R-8D	28.00	28.90	224.0	32.00	42.00	268.2	60.0	28.0	K DCN 27-32.99
DCN 290-232-32R-8D	29.00	29.90	232.0	32.00	42.00	277.8	60.0	29.0	K DCN 27-32.99
DCN 300-240-32R-8D	30.00	30.90	240.0	32.00	42.00	287.4	60.0	30.0	K DCN 27-32.99
DCN 310-248-32R-8D	31.00	31.90	248.0	32.00	42.00	297.0	60.0	31.0	K DCN 27-32.99
DCN 320-256-32R-8D	32.00	32.90	256.0	32.00	42.00	306.5	60.0	32.0	K DCN 27-32.99

• Prior to using the 8xD drill, it is recommended to drill a pre-hole by using a DCN 1.5xD drill or a centering drill. It is not required if HCP drilling head is used

• For user guide and cutting conditions, see pages 490

⁽¹⁾ Do not mount smaller drilling heads other than the specified range of the drill body

For inserts, see pages: FCP (486) • HCP-IQ (483) • ICK (484) • ICK-2M (485) • ICM (484) • ICP (484) • ICP-2M (485) • ICG (487)

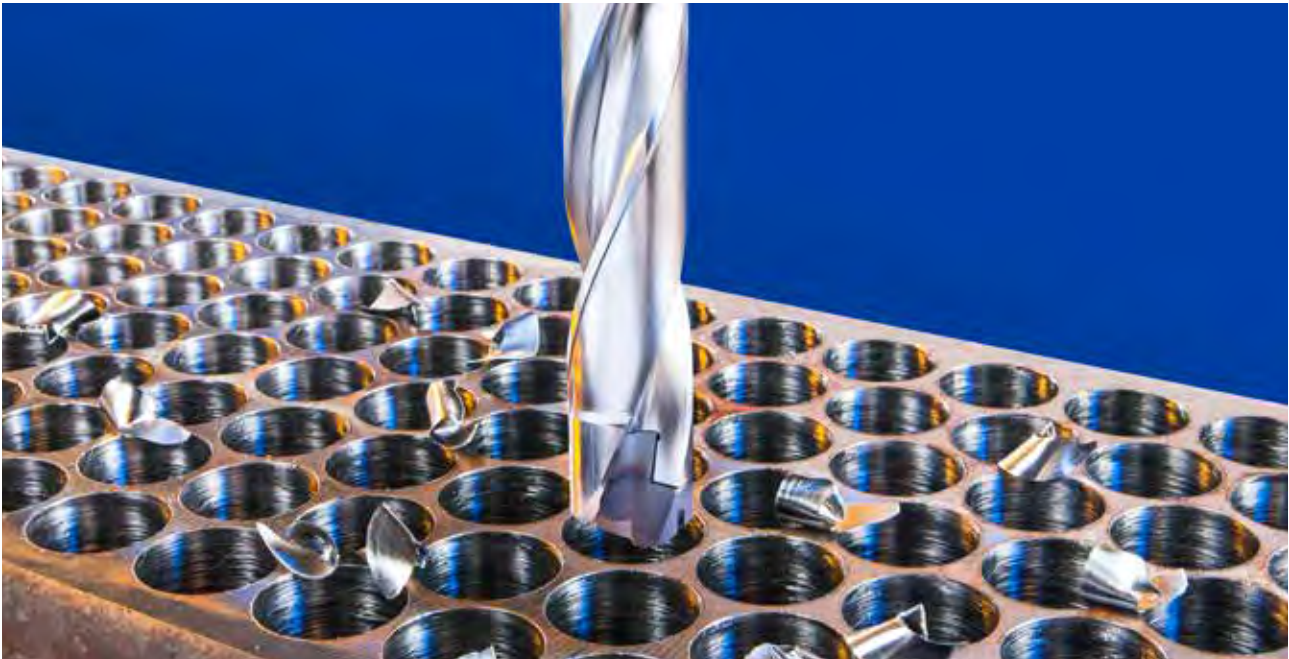

DCN R-12D

Indexable Head Drills with
Coolant Holes and a Cylindrical
Shank, Drilling Depth 12xD

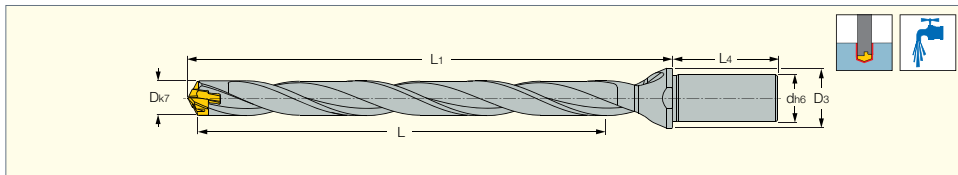

Designation	D _{min} ⁽¹⁾	D _{max}	L	d	D ₃	L ₁	L ₄	Po. Size	
DCN 080-096-12R-12D	8.00	8.40	96.0	12.00	16.00	111.4	45.0	8.0	K DCN 6-9.99
DCN 085-102-12R-12D	8.50	8.90	102.0	12.00	16.00	117.4	45.0	8.0	K DCN 6-9.99
DCN 090-108-12R-12D	9.00	9.40	108.0	12.00	16.00	123.8	45.0	9.0	K DCN 6-9.99
DCN 095-114-12R-12D	9.50	9.90	114.0	12.00	16.00	129.8	45.0	9.0	K DCN 6-9.99
DCN 100-120-16R-12D	10.00	10.40	120.0	16.00	20.00	136.2	48.0	10.0	K DCN 10-13.99
DCN 105-126-16R-12D	10.50	10.90	126.0	16.00	20.00	142.2	48.0	10.0	K DCN 10-13.99
DCN 110-132-16R-12D	11.00	11.40	132.0	16.00	20.00	148.6	48.0	11.0	K DCN 10-13.99
DCN 115-138-16R-12D	11.50	11.90	138.0	16.00	20.00	154.6	48.0	11.0	K DCN 10-13.99
DCN 120-144-16R-12D	12.00	12.40	144.0	16.00	20.00	161.0	48.0	12.0	K DCN 10-13.99
DCN 125-150-16R-12D	12.50	12.90	150.0	16.00	20.00	167.0	48.0	12.0	K DCN 10-13.99
DCN 130-156-16R-12D	13.00	13.40	156.0	16.00	20.00	173.6	48.0	13.0	K DCN 10-13.99
DCN 135-162-16R-12D	13.50	13.90	162.0	16.00	20.00	179.0	48.0	13.0	K DCN 10-13.99
DCN 140-168-16R-12D	14.00	14.40	168.0	16.00	20.00	188.0	48.0	14.0	K DCN 14-17.99
DCN 145-174-16R-12D	14.50	14.90	174.0	16.00	20.00	194.0	48.0	14.0	K DCN 14-17.99
DCN 150-180-20R-12D	15.00	15.90	180.0	20.00	25.00	210.0	50.0	15.0	K DCN 14-17.99
DCN 160-192-20R-12D	16.00	16.90	192.0	20.00	25.00	217.3	50.0	16.0	K DCN 14-17.99
DCN 170-204-20R-12D	17.00	17.90	204.0	20.00	25.00	230.9	50.0	17.0	K DCN 14-17.99
DCN 180-216-25R-12D	18.00	18.90	216.0	25.00	32.00	244.5	56.0	18.0	K DCN 18-21.99
DCN 190-228-25R-12D	19.00	19.90	228.0	25.00	32.00	258.0	56.0	19.0	K DCN 18-21.99
DCN 200-240-25R-12D	20.00	20.90	240.0	25.00	32.00	271.6	56.0	20.0	K DCN 18-21.99
DCN 210-252-25R-12D	21.00	21.90	252.0	25.00	32.00	285.2	56.0	21.0	K DCN 18-21.99
DCN 220-264-25R-12D	22.00	22.90	264.0	25.00	32.00	298.8	56.0	22.0	K DCN 22-26.99
DCN 230-276-32R-12D	23.00	23.90	276.0	32.00	42.00	302.4	60.0	23.0	K DCN 22-26.99
DCN 240-288-32R-12D	24.00	24.90	288.0	32.00	42.00	326.0	60.0	24.0	K DCN 22-26.99
DCN 250-300-32R-12D	25.00	25.90	300.0	32.00	42.00	339.5	60.0	25.0	K DCN 22-26.99
DCN 260-312-32R-12D	26.00	26.90	312.0	32.00	42.00	353.1	60.0	26.0	K DCN 27-32.99
DCN 270-324-32R-12D	27.00	27.90	324.0	32.00	42.00	366.7	60.0	27.0	K DCN 27-32.99
DCN 280-336-32R-12D	28.00	28.90	336.0	32.00	42.00	380.2	60.0	28.0	K DCN 27-32.99
DCN 290-348-32R-12D	29.00	29.90	348.0	32.00	42.00	393.8	60.0	29.0	K DCN 27-32.99
DCN 300-360-32R-12D	30.00	30.90	360.0	32.00	42.00	407.4	60.0	30.0	K DCN 27-32.99
DCN 310-372-32R-12D	31.00	31.90	372.0	32.00	42.00	421.0	60.0	31.0	K DCN 27-32.99
DCN 320-384-32R-12D	32.00	32.90	384.0	32.00	42.00	434.5	60.0	32.0	K DCN 27-32.99

• Prior to using the 12xD drill, it is recommended to drill a pre-hole by using a DCN 1.5xD drill or a centering drill. The HCP drilling head may eliminate the need for a pre-hole • For user guide and cutting conditions, see pages 490

⁽¹⁾ Do not mount smaller drilling heads other than the specified range of the drill body

For inserts, see pages: FCP (486) • HCP-IQ (483) • ICK (484) • ICK-2M (485) • ICM (484) • ICP (484) • ICP-2M (485) • ICG (487)



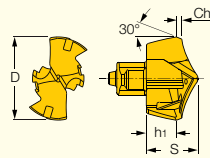

Designation	Dimensions					IC908
	D ⁽¹⁾	S	h ₁	Ch	Po. Size	
HCP...-IQ	6.00-6.40	4.00	2.4	0.5	6.0	•
	6.50-6.90	4.30	2.6	0.5	6.5	•
	7.30-7.90	4.60	2.8	0.6	7.0	•
	8.00-8.90	5.40	3.2	0.7	8.0	•
	9.00-9.90	5.80	3.6	0.8	9.0	•
	10.00-10.90	6.20	3.5	0.8	10.0	•
	11.00-11.90	6.60	3.9	0.9	11.0	•
	12.00-12.90	7.00	3.8	0.9	12.0	•
	13.00-13.90	7.60	4.1	1.0	13.0	•
	14.00-14.90	8.15	4.5	1.1	14.0	•
	15.00-15.90	8.73	4.9	1.2	15.0	•
	16.00-16.90	9.30	5.4	1.1	16.0	•
	17.00-17.90	9.90	5.3	1.5	17.0	•
	18.00-18.90	10.50	5.8	1.4	18.0	•
	19.00-19.90	11.00	6.3	1.3	19.0	•
	20.00-20.90	11.60	6.8	1.0	20.0	•
	21.00-21.90	12.18	7.2	1.2	21.0	•
	22.00-22.90	12.76	7.6	1.2	22.0	•
	23.00-23.90	13.33	7.9	1.3	23.0	•
	24.00-24.90	13.90	8.3	1.4	24.0	•
	25.00-25.90	14.50	8.5	1.1	25.0	•
	26.00-26.90	15.07	9.1	1.0	26.0	•
	27.00-27.90	15.65	9.5	1.1	27.0	•
	28.00-28.90	16.22	9.8	1.1	28.0	•
	29.00-29.90	16.80	10.2	1.1	29.0	•
	30.00-30.90	17.38	10.5	1.2	30.0	•
	31.00-31.90	17.96	11	1.2	31.0	•
	32.00-32.90	18.54	11.2	1.3	32.0	•

⁽¹⁾ The 6.0-25.9 mm drilling heads are available in increments of 0.1 mm, and in increments of 0.5 mm for 26 mm and larger size drilling heads.

• **Ordering example for the HCP 10.3 mm drilling head:** HCP 103-IQ

For tools, see pages: DCN A-1.5D (472) • DCN R-1.5D (473) • DCN A-3D (474) • DCN R-3D (475) • DCNS-3D (476) • DCN A-5D (478) • DCN R-5D (479) • DCNS-5D (477) • DCN A-8D (480) • DCN R-8D (481) • DCN R-12D (482) • MNC (488) • MNCNT-T2 (655)



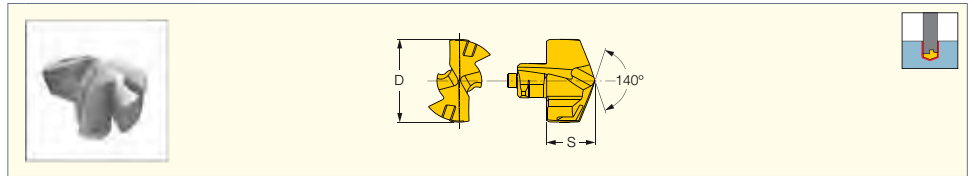

Designation	D ⁽¹⁾	S	Pocket Size	IC908	IC907
	6.0-6.4	4.00	6.0	•	
	6.5-6.9	4.30	6.0	•	
	7.0-7.9	4.60	7.0	•	•
	8.0-8.9	5.40	8.0	•	•
	9.0-9.9	5.80	9.0	•	•
	10.0-10.9	6.20	10.0	•	•
	11.0-11.9	6.60	11.0	•	•
	12.0-12.9	7.00	12.0	•	•
	13.0-13.9	7.60	13.0	•	•
	14.0-14.9	8.15	14.0	•	•
	15.0-15.9	8.73	15.0	•	•
	16.0-16.9	9.30	16.0	•	•
	17.0-17.9	9.90	17.0	•	•
ICP ...	18.0-18.9	10.50	18.0	•	•
ICM ...	19.0-19.9	11.00	19.0	•	•
ICK ...	20.0-20.9	11.60	20.0	•	•
	21.0-21.9	12.20	21.0	•	•
	22.0-22.9	12.80	22.0	•	•
	23.0-23.9	13.40	23.0	•	•
	24.0-24.9	14.00	24.0	•	•
	25.0-25.9	14.50	25.0	•	•
	26.00-26.9	15.30	26.0	•	
	27.00-27.9	16.20	27.0	•	
	28.00-28.9	17.00	28.0	•	
	29.00-29.9	17.90	29.0	•	
	30.00-30.9	18.70	30.0	•	
	31.00-31.9	19.60	31.0	•	
	32.00-32.9	20.40	32.0	•	

- **ICP** for use on carbon and alloy steel (ISO P). The drill head has a honed cutting edge
 - **ICM** for use on stainless and high temperature alloys (ISO M). The drill head features a T-land on the cutting edge
 - **ICK** for use on cast iron (ISO K). The drill head is produced with a ground chamfer and a honed cutting edge
 - IC907 is available for several ICM and ICK drilling heads
- ⁽¹⁾ Drilling heads are available in increments of 0.1 mm

For tools, see pages: DCN A-1.5D (472) • DCN R-1.5D (473) • DCN A-3D (474) • DCN R-3D (475) • DCNS-3D (476) • DCN A-5D (478) • DCN R-5D (479) • DCNS-5D (477) • DCN A-8D (480) • DCN R-8D (481) • DCN R-12D (482) • MNC (488) • MNCNT-T2 (655)



ICP-2MICK-2M

Double Margin Drilling Heads for DCN Drills for High Surface Finish

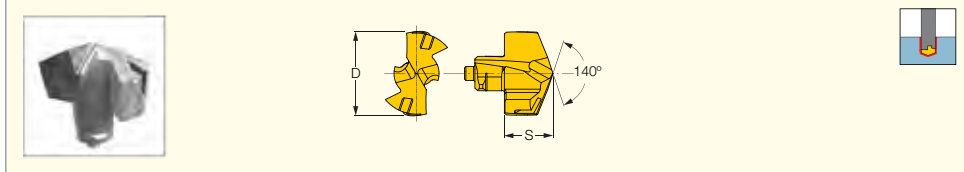

Designation	Dimensions			IC908
	D ⁽¹⁾	S	Pocket Size	
ICP-2M... ICK-2M...	6.0-6.4	4.00	6.0	•
	6.5-6.9	4.30	6.5	•
	7.00-7.90	4.60	7.0	•
	8.00-8.90	5.40	8.0	•
	9.00-9.90	5.80	9.0	•
	10.00-10.90	6.20	10.0	•
	11.00-11.90	6.60	11.0	•
	12.00-12.90	7.00	12.0	•
	13.00-13.90	7.60	13.0	•
	14.00-14.90	8.15	14.0	•
	15.00-15.90	8.73	15.0	•
	16.00-16.90	9.30	16.0	•
	17.00-17.90	9.90	17.0	•
	18.00-18.90	10.50	18.0	•
	19.00-19.90	11.00	19.0	•
	20.00-20.90	11.60	20.0	•
	21.00-21.90	12.20	21.0	•
	22.00-22.90	12.80	22.0	•
	23.00-23.90	13.40	23.0	•
	24.00-24.90	14.00	24.0	•
25.00-25.90	14.50	25.0	•	

- **ICP** for use on carbon and alloy steel (ISO P).
The drill head has a honed cutting edge
- **ICK** for use on cast iron (ISO K).
The drill head is produced with a ground chamfer and a honed cutting edge
- Can provide high surface finish of up to 1.6 Ra; hole cylindricity and straightness of up to 0.05 mm
- Ordering example for the ICP 13.3 mm drilling head: ICP 133-2M IC908
- ⁽¹⁾ Drilling heads are available in increments of 0.1 mm

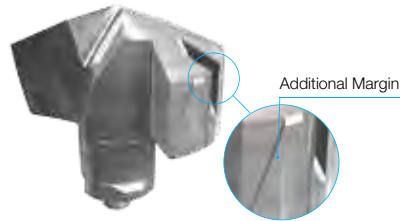

For tools, see pages: DCN A-1.5D (472) • DCN R-1.5D (473) • DCN A-3D (474) • DCN R-3D (475) • DCNS-3D (476) • DCN A-5D (478) • DCN R-5D (479) • DCNS-5D (477) • DCN A-8D (480) • DCN R-8D (481) • DCN R-12D (482) • MNCNT-T2 (655)



SUMOCHAM
FLAT HEAD

FCP

Exchangeable Flat Bottom DCN
Drill Heads for Steel and Cast Iron
(ISO P and ISO K Materials)

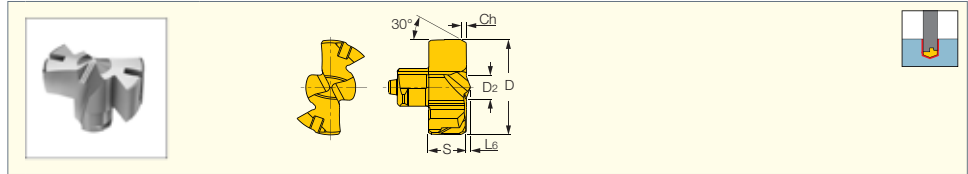

Designation	Dimensions						IC908
	D ⁽¹⁾	D ₂	S	L ₆	Ch	Po. Size	
FCP...	6.00-6.40	1.15	2.80	0.21	0.4	6.0	•
	6.50-6.90	1.54	3.00	0.28	0.4	6.5	•
	7.00-7.40	1.54	3.30	0.28	0.4	7.0	•
	7.50-7.90	1.54	3.70	0.28	0.4	7.0	•
	8.00-8.90	2.44	4.00	0.39	0.7	8.0	•
	9.00-9.90	2.55	4.20	0.41	0.7	9.0	•
	10.00-10.90	2.89	4.40	0.47	0.7	10.0	•
	11.00-11.90	2.98	4.60	0.54	0.7	11.0	•
	12.00-12.90	3.13	4.80	0.56	0.7	12.0	•
	13.00-13.90	3.52	5.10	0.58	0.7	13.0	•
	14.00-14.90	3.81	5.50	0.61	0.7	14.0	•
	15.00-15.90	4.24	5.93	0.65	0.7	15.0	•
	16.00-16.90	4.06	6.30	0.69	0.7	16.0	•
	17.00-17.90	4.14	6.60	0.70	0.7	17.0	•
	18.00-18.90	4.16	6.88	0.72	0.7	18.0	•
	19.00-19.90	4.25	7.20	0.74	0.7	19.0	•
	20.00-20.90	6.56	8.20	1.07	0.7	20.0	•
	21.00-21.90	6.92	8.60	1.09	0.7	21.0	•
	22.00-22.90	7.13	8.90	1.11	0.7	22.0	•
	23.00-23.90	7.42	9.30	1.13	0.7	23.0	•
	24.00-24.90	7.45	9.70	1.16	0.7	24.0	•
	25.00-25.90	7.54	10.10	1.20	0.7	25.0	•
	26.00-26.90	8.00	9.70	1.30	0.7	26.0	•
	27.00-27.90	8.10	11.00	1.40	0.7	27.0	•
	28.00-28.90	8.80	11.00	1.50	0.7	28.0	•
	29.00-29.90	9.00	12.00	1.50	0.7	29.0	•
	30.00-30.90	9.10	12.00	1.50	0.7	30.0	•
	31.00-31.90	9.10	12.00	1.50	0.7	31.0	•
	32.00-32.90	9.80	13.00	1.60	0.7	32.0	•

(1) The drilling heads are available in increments of 0.1 mm for the 8.0-25.9 diameters and in increments of 0.5 mm for the 26.0 mm and larger • Ordering example for FCP 10.3 mm drilling head: FCP 103

For tools, see pages: DCN A-1.5D (472) • DCN A-3D (474) • DCN A-5D (478) • DCN A-8D (480) • DCN R-1.5D (473) • DCN R-12D (482) • DCN R-3D (475) • DCN R-5D (479) • DCN R-8D (481) • DCNS-3D (476) • DCNS-5D (477)



ICG

Exchangeable Chip Splitting Drill
Heads for Stainless and Alloyed Steel

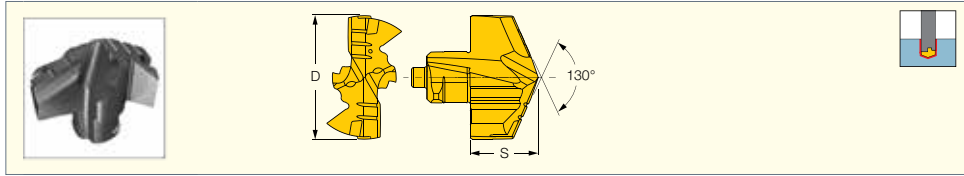

Designation	Dimensions			IC908
	D	S	Po. Size	
ICG 120	12.00	6.70	12.0	●
ICG 125	12.50	6.70	12.0	●
ICG 130	13.00	7.30	13.0	●
ICG 135	13.50	7.30	13.0	●
ICG 140	14.00	7.85	14.0	●
ICG 142	14.20	7.85	14.0	●
ICG 145	14.50	7.85	14.0	●
ICG 150	15.00	8.43	15.0	●
ICG 155	15.50	8.43	15.0	●
ICG 160	16.00	9.00	16.0	●
ICG 163	16.30	9.00	16.0	●
ICG 165	16.50	9.00	16.0	●
ICG 170	17.00	9.60	17.0	●
ICG 175	17.50	9.60	17.0	●
ICG 177	17.70	9.60	17.0	●
ICG 180	18.00	10.20	18.0	●
ICG 185	18.50	10.20	18.0	●
ICG 190	19.00	10.70	19.0	●
ICG 193	19.30	10.70	19.0	●
ICG 195	19.50	10.70	19.0	●
ICG 200	20.00	11.20	20.0	●
ICG 203	20.30	11.20	20.0	●
ICG 205	20.50	11.20	20.0	●
ICG 210	21.00	11.78	21.0	●
ICG 215	21.50	11.78	21.0	●
ICG 220	22.00	12.36	22.0	●
ICG 225	22.50	12.36	22.0	●
ICG 230	23.00	12.93	23.0	●
ICG 235	23.50	12.93	23.0	●
ICG 240	24.00	13.50	24.0	●
ICG 245	24.50	13.50	24.0	●
ICG 250	25.00	14.10	25.0	●
ICG 253	25.30	14.10	25.0	●
ICG 257	25.70	14.10	25.0	●
ICG 259	25.90	14.10	25.0	●

For tools, see pages: DCN A-1.5D (472) • DCN R-1.5D (473) • DCN A-3D (474) • DCN R-3D (475) • DCNS-3D (476) • DCN A-5D (478) • DCN R-5D (479)
• DCNS-5D (477) • DCN A-8D (480) • DCN R-8D (481) • DCN R-12D (482) • MNC (488) • MNCNT-T2 (655)

COMBICHAM

MNC

Large Diameter Indexable Drills
with a Pilot Drilling Head and One
Flat Shank, Drilling Depth 5xD

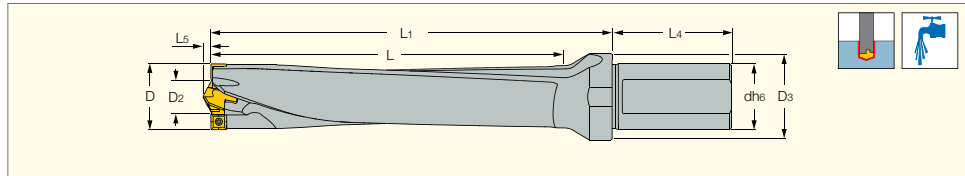

Designation	D	D ₂	L	L ₁	L ₄	L ₅	d	D ₃	Insert ⁽¹⁾	Insert ⁽²⁾
MNC 260-130 A32-150-06-5D	26.00	15.00	130.0	164.0	60.0	2.95	32.00	42.00	SOGX 060304-W	ICP 150
MNC 265-132 A32-155-06-5D	26.50	15.50	132.0	164.0	60.0	3.05	32.00	42.00	SOGX 060304-W	ICP 155
MNC 270-135 A32-160-06-5D	27.00	16.00	135.0	167.0	60.0	3.10	32.00	42.00	SOGX 060304-W	ICP 160
MNC 280-140 A32-170-06-5D	28.00	17.00	140.0	171.0	60.0	3.25	32.00	42.00	SOGX 060304-W	ICP 170
MNC 290-145 A32-160-07-5D	29.00	16.00	145.0	177.0	60.0	3.10	32.00	42.00	SOGX 070305-W	ICP 160
MNC 295-148 A32-165-07-5D	29.50	16.50	148.0	180.0	60.0	3.20	32.00	42.00	SOGX 070305-W	ICP 165
MNC 300-150 A32-165-07-5D	30.00	16.50	150.0	183.0	60.0	3.20	32.00	42.00	SOGX 070305-W	ICP 165
MNC 310-155 A32-175-07-5D	31.00	17.50	155.0	190.0	60.0	3.35	32.00	42.00	SOGX 070305-W	ICP 175
MNC 320-160 A32-185-07-5D	32.00	18.50	160.0	195.0	60.0	3.50	32.00	42.00	SOGX 070305-W	ICP 185
MNC 330-165 A32-175-09-5D	33.00	17.50	165.0	200.0	60.0	3.65	32.00	42.00	SOGT 09T306-W	ICP 175
MNC 340-170 A32-180-09-5D	34.00	18.00	170.0	205.0	60.0	3.70	32.00	42.00	SOGT 09T306-W	ICP 180
MNC 350-175 A32-189-09-5D	35.00	18.90	175.0	210.0	60.0	3.85	32.00	42.00	SOGT 09T306-W	ICP 189
MNC 360-180 A32-190-10-5D	36.00	19.00	180.0	215.0	60.0	3.85	32.00	42.00	SOGT 100408-W	ICP 190
MNC 370-185 A32-200-10-5D	37.00	20.00	185.0	220.0	60.0	4.00	32.00	42.00	SOGT 100408-W	ICP 200
MNC 375-188 A32-205-10-5D	37.50	20.50	188.0	223.0	60.0	4.10	32.00	42.00	SOGT 100408-W	ICP 205
MNC 380-190 A40-209-10-5D	38.00	20.90	190.0	227.0	68.0	4.15	40.00	50.00	SOGT 100408-W	ICP 209
MNC 390-195 A40-215-10-5D	39.00	21.50	195.0	233.0	68.0	4.25	40.00	50.00	SOGT 100408-W	ICP 215
MNC 400-200 A40-225-10-5D	40.00	22.50	200.0	240.0	68.0	4.40	40.00	50.00	SOGT 100408-W	ICP 225
MNC 405-203 A40-235-10-5D	40.50	23.50	203.0	243.0	68.0	4.55	40.00	50.00	SOGT 100408-W	ICP 235
MNC 410-205 A40-239-10-5D	41.00	23.90	205.0	245.0	68.0	4.65	40.00	50.00	SOGT 100408-W	ICP 239
MNC 420-210 A40-249-10-5D	42.00	24.90	210.0	250.0	68.0	4.75	40.00	50.00	SOGT 100408-W	ICP 249
MNC 430-215 A40-259-10-5D	43.00	25.90	215.0	258.0	68.0	5.00	40.00	50.00	SOGT 100408-W	ICP 259
MNC 440-220 A40-210-12-5D	44.00	21.00	220.0	259.0	68.0	5.15	40.00	50.00	SOGT 120408-W	ICP 210
MNC 450-225 A40-219-12-5D	45.00	21.90	225.0	264.0	68.0	5.35	40.00	50.00	SOGT 120408-W	ICP 219
MNC 460-230 A40-229-12-5D	46.00	22.90	230.0	269.0	68.0	5.50	40.00	50.00	SOGT 120408-W	ICP 229
MNC 470-235 A40-239-12-5D	47.00	23.90	235.0	275.0	68.0	5.65	40.00	50.00	SOGT 120408-W	ICP 239
MNC 480-240 A40-249-12-5D	48.00	24.90	240.0	279.0	68.0	7.75	40.00	50.00	SOGT 120408-W	ICP 249
MNC 490-245 A40-259-12-5D	49.00	25.90	245.0	286.0	68.0	6.00	40.00	50.00	SOGT 120408-W	ICP 259
MNC 500-250 A40-269-12-5D	50.00	26.90	250.0	291.0	68.0	6.10	40.00	50.00	SOGT 120408-W	ICP 269





• Hole tolerance: D+0.10/-0.05 in average conditions. However, it can be higher or lower according to machine and tooling conditions • Intermediate sizes are available on request • For user guide and cutting conditions, see pages 490, 498

(1) Outer insert

(2) Central insert

For inserts, see pages: HCP-IQ (483) • ICP (484) • SOGT-W (489) • SOGX-W (489) • ICG (487)

Spare Parts

Designation					
MNC 260-130 A32-150-06-5D	SR 34-508/L	T-7/51			K MNC MULTI
MNC 265-132 A32-155-06-5D	SR 34-508/L	T-7/51			K MNC MULTI
MNC 270-135 A32-160-06-5D	SR 34-508/L	T-7/51			K MNC MULTI
MNC 280-140 A32-170-06-5D	SR 34-508/L	T-7/51			K MNC MULTI
MNC 290-145 A32-160-07-5D	SR 14-560	T-8/53			K MNC MULTI
MNC 295-148 A32-165-07-5D	SR 14-560	T-8/53			K MNC MULTI
MNC 300-150 A32-165-07-5D	SR 14-560	T-8/53			K MNC MULTI
MNC 310-155 A32-175-07-5D	SR 14-560	T-8/53			K MNC MULTI
MNC 320-160 A32-185-07-5D	SR 14-560	T-8/53			K MNC MULTI
MNC 330-165 A32-175-09-5D	SR 34-506		BLD T09/M7-SW4	SW4-SD	K MNC MULTI
MNC 340-170 A32-180-09-5D	SR 34-506		BLD T09/M7-SW4	SW4-SD	K MNC MULTI
MNC 350-175 A32-189-09-5D	SR 34-506		BLD T09/M7-SW4	SW4-SD	K MNC MULTI
MNC 360-180 A32-190-10-5D	SR 14-571		BLD T10/S7	SW6-SD	K MNC MULTI
MNC 370-185 A32-200-10-5D	SR 14-571		BLD T10/S7	SW6-SD	K MNC MULTI
MNC 375-188 A32-205-10-5D	SR 14-571		BLD T10/S7	SW6-SD	K MNC MULTI
MNC 380-190 A40-209-10-5D	SR 14-571		BLD T10/S7	SW6-SD	K MNC MULTI
MNC 390-195 A40-215-10-5D	SR 14-571		BLD T10/S7	SW6-SD	K MNC MULTI
MNC 400-200 A40-225-10-5D	SR 14-571		BLD T10/S7	SW6-SD	K MNC MULTI
MNC 405-203 A40-235-10-5D	SR 14-571		BLD T10/S7	SW6-SD	K MNC MULTI
MNC 410-205 A40-239-10-5D	SR 14-571		BLD T10/S7	SW6-SD	K MNC MULTI
MNC 420-210 A40-249-10-5D	SR 14-571		BLD T10/S7	SW6-SD	K MNC MULTI
MNC 430-215 A40-259-10-5D	SR 14-571		BLD T10/S7	SW6-SD	K MNC MULTI
MNC 440-220 A40-210-12-5D	SR 14-544/S		BLD T15/S7	SW6-SD	K MNC MULTI
MNC 450-225 A40-219-12-5D	SR 14-544/S		BLD T15/S7	SW6-SD	K MNC MULTI
MNC 460-230 A40-229-12-5D	SR 14-544/S		BLD T15/S7	SW6-SD	K MNC MULTI
MNC 470-235 A40-239-12-5D	SR 14-544/S		BLD T15/S7	SW6-SD	K MNC MULTI
MNC 480-240 A40-249-12-5D	SR 14-544/S		BLD T15/S7	SW6-SD	K MNC MULTI
MNC 490-245 A40-259-12-5D	SR 14-544/S		BLD T15/S7	SW6-SD	K MNC MULTI
MNC 500-250 A40-269-12-5D	SR 14-544/S		BLD T15/S7	SW6-SD	K MNC MULTI

COMBICHAM

SOGX-W

Precision Ground Inserts for
MNC Drills with DT General Use
Chipformer and a Wiper

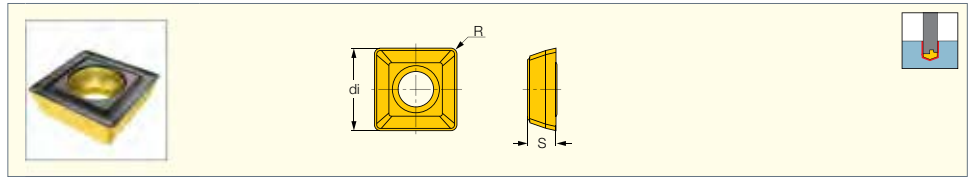

Designation	Dimensions			IC808
	di	S	R	
SOGX 050204-W	5.40	2.40	0.40	•
SOGX 060304-W	6.20	3.20	0.40	•
SOGX 070305-W	7.70	3.60	0.50	•

For tools, see pages: MNC (488)

COMBICHAM

SOGT-W

Precision Ground Inserts for
MNC Drills with DT General Use
Chipformer and a Wiper

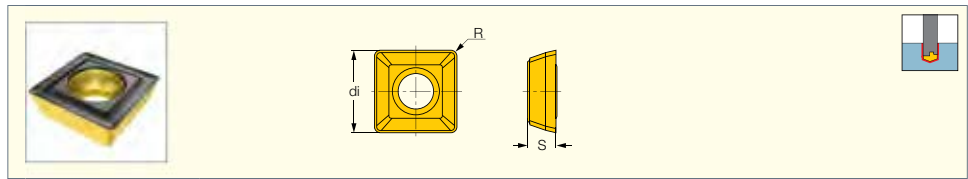

Designation	Dimensions			IC808
	di	S	R	
SOGT 09T306-W	9.00	3.81	0.60	•
SOGT 100408-W	9.80	4.30	0.80	•
SOGT 120408-W	12.70	4.76	0.80	•

For tools, see pages: MNC (488)



Drilling Heads

- **SUMOCHAM** features four different standard drill head geometries, designed for optimal performance and high reliability when used on various materials.
- **ICP** for use on carbon and alloy steel (**ISO P**). The drill head has a honed cutting edge.
- **ICK** for use on cast iron (**ISO K**). The drill head is produced with a ground chamfer and a honed cutting edge.
- **ICM** for use on stainless and high temperature alloys (**ISO M**). The drill head features a T-land on the cutting edge.
- The **ICP**, **ICK** and **ICM** drilling heads are available in 0.1 mm drilling diameter increments.

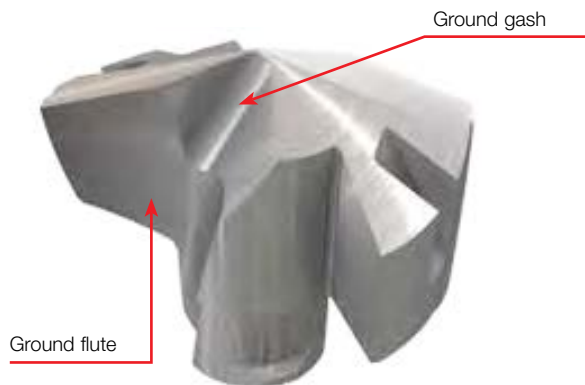
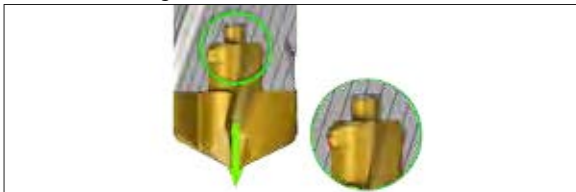

The drill head has ground flutes for smooth, uninterrupted chip flow and a ground gash for improved penetration.

To prevent the insert from being pulled out during the drilling process, there is an axial stopper in the pocket. It is effective even after the clamping force has been lost (which may happen when the drill's pocket wears out).

General Recommendations

- **SUMOCHAM** drills can be used in any type of adaptation. However, concentric adaptation such as spring collets and hydraulic chucks are advantageous for better runout. When machining high temperature alloys or applying very high machining loads, it is advisable to use strong gripping adapters such as endmill holders, power or hydraulic chucks.
- Dry drilling should not be performed under any circumstances.
- Semi-synthetic or emulsion lubricants are recommended in order to extend tool life.
- It is essential to use internal coolant in all **SUMOCHAM** applications. In the event of low coolant pressure or when used in a stationary application, adding an external coolant can improve tool life.
- When only external coolant can be applied, it is recommended to drill into maximum depth of 2xD hole depth to diameter ratio.
- When using **M.Q.L.** coolant, there is no need for special accessories. For smooth **M.Q.L.** coolant flow there is a spherical cavity on the rear side of the drill shank.
- There is a special plug with an internal thread for a coolant connection used on stationary machines that can be pressed into the cavity on the back end of the drill.



Shank Diameter	Plug	Internal Thread
12	DL-12	G 1/16
16	DL-16	G 1/16
20	DL-20	G 1/8
25	DL-25	G 1/8
32	DL-32	G 1/8

- When drilling stainless steel or high temperature alloys using the **ICM** drilling head, it is highly recommended to apply high pressure oil or 7-10% mineral or vegetable based oil emulsion.

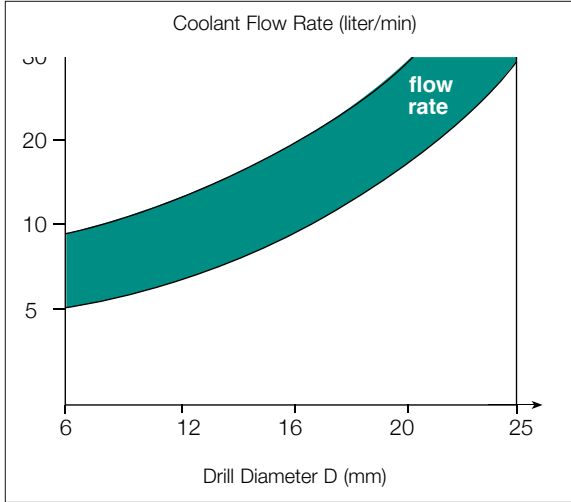

- Following is the recommended coolant flow rate and pressure.

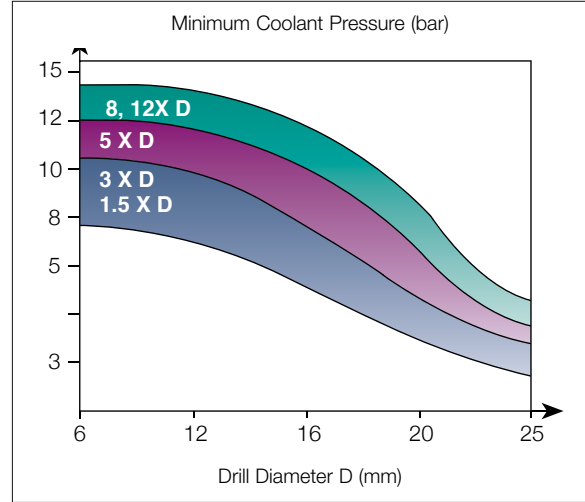

- For optimal performance, it is recommended to adjust runout of outer points or chisel with a maximum of 0.02 mm. Large runout will influence drill performance tool life and hole quality.
- No setup time is needed after indexing the **SUMOCHAM** drill head.

- SUMOCHAM** drills can be used either on milling centers or lathe machines.
- When using **SUMOCHAM** drill in stationary (lathe) applications, we recommend using the **ISCAR GYRO** device or eccentric sleeve to reduce misalignment. Misalignment will cause poor performance of the **SUMOCHAM** drill or even tool breakage.

1 Pre-hole 0.5xD deep for centering

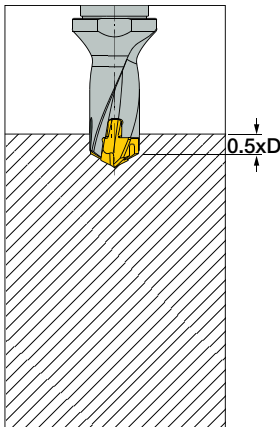

2 Slow rotation and feed while entering to the pre-hole

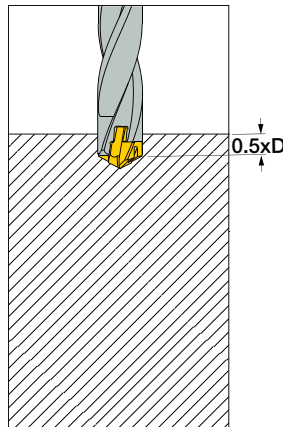

3 Maintain for 2-3 seconds and activate the cooling system

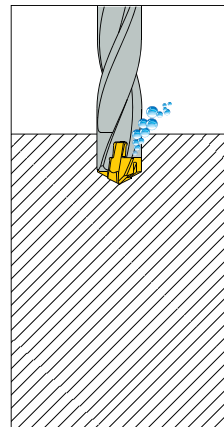

4 Continue drilling at recommended cutting conditions

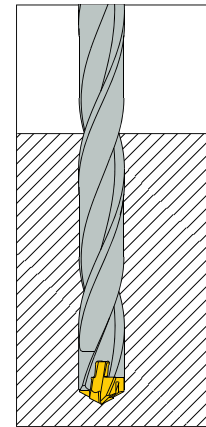

- Prior to using 8xD or 12xD drills, it is recommended to drill a 0.5xD pre-hole using a short or centering drill. Enter the pre-hole at slow speed and feed until 2-5 mm from its bottom. Start the cooling system and increase rotation to recommended drilling speed. Hold for 2-3 seconds, then, continue at the recommended drilling feed.

PreHole Adjustment

Hole \ PreHole	ICP	ICK	HCP	FCP
ICP				
ICK				
HCP				
FCP				

Drilling Head Mounting Procedure

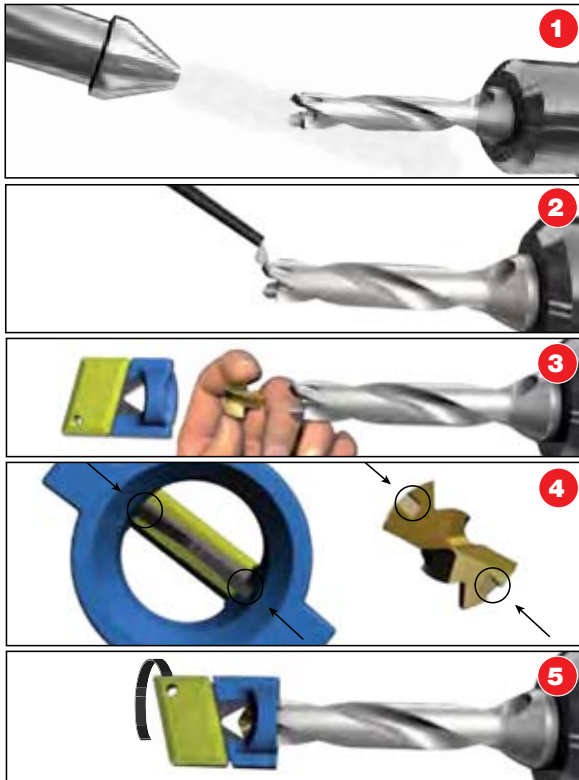

Coolant Recommendations

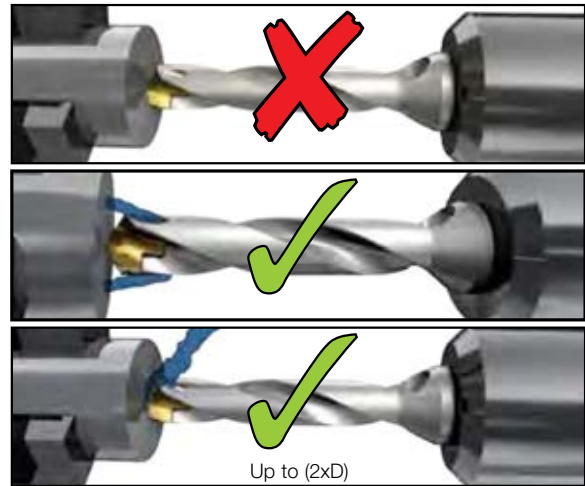

Maximum Runout, Misalignment

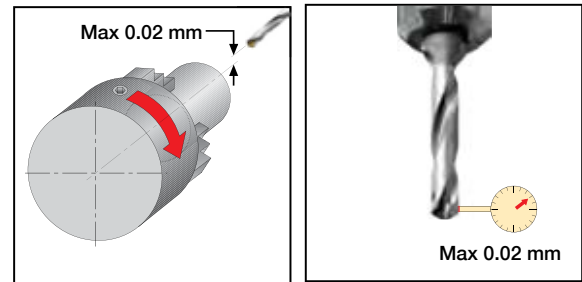

K DCN MULTI

The optional **K DCN MULTI** key enables clamping all currently available **SUMOCHAM** drilling heads in a 6-26.9 mm diameter range.

Indication of Drill Head Wear

Wear Limit

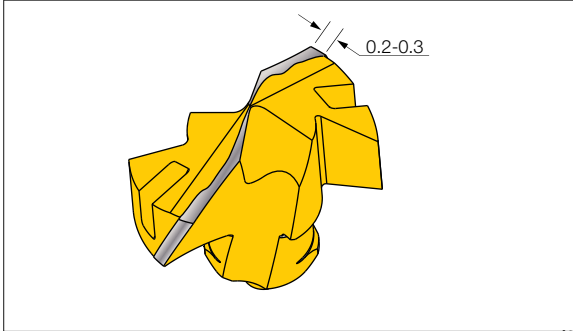

Power Restriction

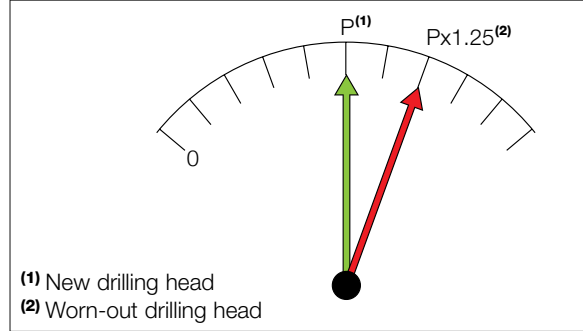

Diameter Change

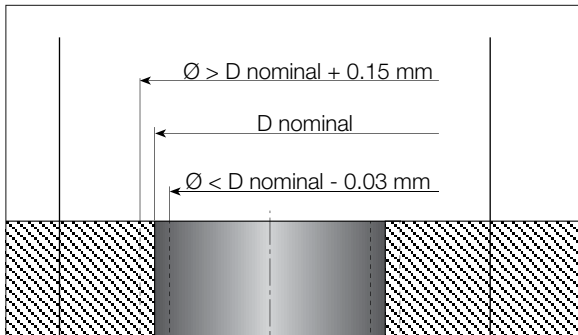

Surface Finish Declines

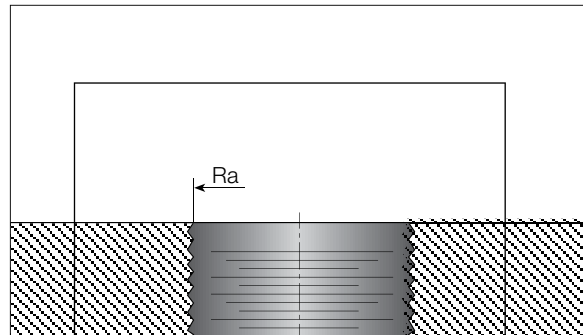

Vibration Noise Drastically Increases

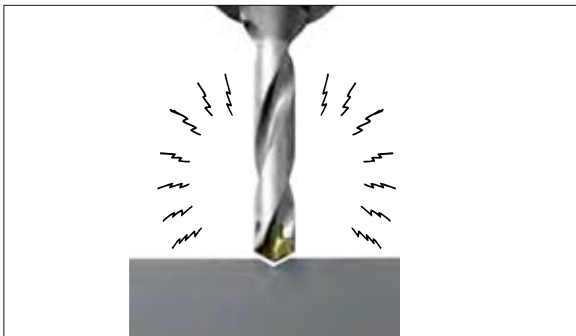

Drilling Limitations



Material Groups

ISO	Material	Condition	Tensile Strength [N/mm ²]	Hardness HB	Material No.	
P	Non-alloy steel and cast steel, free cutting steel	< 0.25 %C	Annealed	420	125	1
		>= 0.25 %C	Annealed	650	190	2
		< 0.55 %C	Quenched and tempered	850	250	3
		>= 0.55 %C	Annealed	750	220	4
			Quenched and tempered	1000	300	5
	Low alloy steel and cast steel (less than 5% of alloying elements)		Annealed	600	200	6
		Quenched and tempered		930	275	7
				1000	300	8
				1200	350	9
	High alloyed steel, cast steel, and tool steel		Annealed	680	200	10
			Quenched and tempered	1100	325	11
K	Grey cast iron (GG)	Ferritic/pearlitic		180	15	
		Pearlitic		260	16	
	Nodular cast iron (GGG)	Ferritic		160	17	
		Pearlitic		250	18	
	Malleable cast iron	Ferritic		130	19	
		Pearlitic		230	20	

- When using external coolant supply only, reduce cutting speed by 10%.
- Use internal coolant supply when machining austenitic stainless steel.

Recommended Machining Conditions

		SUMOCHAM							
		Feed vs. Drill Diameter							
Mtl. No.	V m/min	D=6-7.9	D=8-9.9	D=10-11.9	D=12-13.9	D=14-15.9	D=16-19.9	D=20-25.9	D=26-32.9
		mm/rev							
1	80- 110 -140								
2	80- 105 -130	0.09	0.12	0.15	0.18	0.20	0.25	0.25	0.30
3	80- 100 -120	0.11	0.17	0.21	0.24	0.27	0.35	0.35	0.40
4	70- 90 -110	0.13	0.22	0.28	0.30	0.35	0.45	0.45	0.50
5	50- 70 -90								
6	80- 100 -120	0.09	0.12	0.14	0.16	0.18	0.23	0.25	0.30
7	70- 90 -110	0.12	0.18	0.21	0.24	0.26	0.31	0.35	0.40
8	50- 70 -90	0.15	0.25	0.28	0.32	0.35	0.40	0.45	0.50
9	40- 55 -70								
10	50- 70 -90	0.09	0.12	0.12	0.15	0.18	0.20	0.22	0.25
11	40- 60 -80	0.11	0.16	0.17	0.20	0.23	0.25	0.27	0.30
		0.12	0.20	0.22	0.25	0.28	0.30	0.33	0.35
15	90- 125 -160								
16	80- 110 -140	0.12	0.15	0.20	0.25	0.30	0.35	0.35	0.40
17	90- 135 -180	0.15	0.22	0.27	0.32	0.37	0.45	0.47	0.50
18	80- 110 -140	0.18	0.30	0.35	0.40	0.45	0.55	0.60	0.60
19	90- 125 -160								
20	80- 110 -140								

■ Recommended cutting data

(*) For workpiece materials list, see pages 1008-1043. As a starting value, the middle of the recommended machining range should be used.

Then, according to the wear results, conditions can be changed to optimize performance.

The data refers to IC908

No need to reduce the cutting parameters while using 8XD and up holders

Material Groups

ISO	Material	Condition	Tensile Strength [N/mm ²]	Hardness HB	Material No.		
P	Non-alloy steel and cast steel, free cutting steel	< 0.25 %C	Annealed	420	125	1	
		>= 0.25 %C	Annealed	650	190	2	
		< 0.55 %C	Quenched and tempered	850	250	3	
		>= 0.55 %C	Annealed	750	220	4	
			Quenched and tempered	1000	300	5	
	Low alloy steel and cast steel (less than 5% of alloying elements)		Annealed	600	200	6	
			Quenched and tempered	930	275	7	
				1000	300	8	
				1200	350	9	
	High alloyed steel, cast steel, and tool steel		Annealed	680	200	10	
			Quenched and tempered	1100	325	11	
	Stainless steel and cast steel		Ferritic/martensitic	680	200	12	
			Martensitic	820	240	13	
M	Stainless steel	Austenitic	600	180	14		
K	Grey cast iron (GG)		Ferritic/pearlitic		180	15	
			Pearlitic		260	16	
	Nodular cast iron (GGG)		Ferritic		160	17	
			Pearlitic		250	18	
	Malleable cast iron		Ferritic		130	19	
			Pearlitic		230	20	
N	Aluminum-wrought alloy		Not cureable		60	21	
			Cured		100	22	
	Aluminum-cast, alloyed	<=12% Si		Not cureable		75	23
				Cured		90	24
		>12% Si		High temperature		130	25
	Copper alloys	>1% Pb		Free cutting		110	26
				Brass		90	27
				Electrolytic copper		100	28
	Non-metallic		Duroplastics, fiber plastics			29	
		Hard rubber			30		
S	High temp. alloys	Fe based		Annealed		200	31
				Cured		280	32
		Ni or Co based		Annealed		250	33
				Cured		350	34
				Cast		320	35
	Titanium Ti alloys			RM 400		36	
			Alpha+beta alloys cured	RM 1050		37	
H	Hardened steel		Hardened		55 HRC	38	
			Hardened		60 HRC	39	

- When using external coolant supply only, reduce cutting speed by 10%
- Use internal coolant supply when machining austenitic stainless steel
- When using more than 5XD drill ratio, reduce cutting parameters by 10%

Recommended Machining Conditions

		SUMOCHAM							
		Feed vs. Drill Diameter							
Mtl. No. ⁽¹⁾	V m/min	D=6-7.9	D=8-9.9	D=10-11.9	D=12-13.9	D=14-15.9	D=16-19.9	D=20-25.9	D=26-32.9
		mm/rev							
1	80-110-140								
2	80- 105 -130	0.09	0.12	0.15	0.18	0.20	0.25	0.25	0.30
3	80- 100 -120	0.11	0.17	0.21	0.24	0.27	0.35	0.35	0.40
4	70- 90 -110	0.13	0.22	0.28	0.30	0.35	0.45	0.45	0.50
5	50- 70 -90								
6	80- 100 -120	0.09	0.12	0.14	0.16	0.18	0.23	0.25	0.30
7	70- 90 -110	0.12	0.18	0.21	0.24	0.26	0.31	0.35	0.40
8	50- 70 -90	0.15	0.25	0.28	0.32	0.35	0.40	0.45	0.50
9	40- 55 -70								
10	50- 70 -90	0.09	0.12	0.12	0.15	0.18	0.20	0.22	0.25
11	40- 60 -80	0.11	0.16	0.17	0.20	0.23	0.25	0.27	0.30
		0.12	0.20	0.22	0.25	0.28	0.30	0.33	0.35
12	40- 55 -70	0.08	0.10	0.12	0.14	0.16	0.16	0.18	0.20
13	40- 55 -70	0.09	0.12	0.15	0.17	0.20	0.21	0.24	0.27
		0.10	0.15	0.18	0.20	0.24	0.26	0.30	0.35
14	30- 50 -70	0.08	0.10	0.12	0.14	0.16	0.16	0.18	0.20
		0.09	0.12	0.15	0.17	0.20	0.21	0.24	0.27
		0.10	0.15	0.18	0.20	0.24	0.26	0.30	0.35
15	90- 125 -160								
16	80- 110 -140	0.12	0.15	0.20	0.25	0.30	0.35	0.35	0.40
17	90- 135 -180	0.15	0.22	0.27	0.32	0.37	0.45	0.47	0.50
18	80- 110 -140	0.18	0.30	0.35	0.40	0.45	0.55	0.60	0.60
19	90- 125 -160								
20	80- 110 -140								
21									
22									
23	90- 155 -220								
24			0.20	0.25	0.30	0.35	0.40	0.45	0.50
25	80- 120 -160		0.27	0.32	0.37	0.42	0.50	0.57	0.67
26			0.35	0.40	0.45	0.50	0.60	0.70	0.75
27	90- 155 -220								
28									
29									
30									
31	30- 45 -60								
32		0.05	0.06	0.08	0.10	0.12	0.12	0.14	0.16
33	20- 35 -50	0.06	0.08	0.10	0.12	0.15	0.16	0.18	0.20
34		0.07	0.11	0.13	0.15	0.18	0.20	0.22	0.25
35									
36	20- 35 -50	0.05	0.06	0.08	0.10	0.12	0.14	0.16	0.18
37		0.06	0.09	0.11	0.14	0.16	0.18	0.20	0.22
		0.07	0.12	0.15	0.18	0.20	0.22	0.25	0.27
38	20- 35 -50	0.05	0.06	0.08	0.10	0.12	0.14	0.16	0.18
39		0.06	0.09	0.11	0.14	0.16	0.18	0.20	0.22
		0.07	0.12	0.15	0.18	0.20	0.22	0.25	0.27

■ Recommended cutting data

⁽¹⁾ For workpiece materials list, see pages 1008-1043. As a starting value, the middle of the recommended machining range should be used.

Then, according to the wear results, conditions can be changed to optimize performance.

The data refers to IC908

Machining Data for MNC drills

ISO	Material	Condition	Tensile Strength [N/mm ²]	Hardness HB	Material No.	
P	Non-alloy steel and cast steel, free cutting steel	< 0.25 %C	Annealed	420	125	1
		>= 0.25 %C	Annealed	650	190	2
		< 0.55 %C	Quenched and tempered	850	250	3
		>= 0.55 %C	Annealed	750	220	4
	Low alloy steel and cast steel (less than 5% of alloying elements)	Quenched and tempered		1000	300	5
		Annealed		600	200	6
		Quenched and tempered		930	275	7
				1000	300	8
				1200	350	9
	High alloyed steel, cast steel, and tool steel	Annealed		680	200	10
		Quenched and tempered		1100	325	11
	Stainless steel and cast steel	Ferritic/martensitic		680	200	12
		Martensitic		820	240	13
M	Stainless steel	Austenitic	600	180	14	
K	Grey cast iron (GG)	Ferritic/pearlitic		180	15	
		Pearlitic		260	16	
	Nodular cast iron (GGG)	Ferritic		160	17	
		Pearlitic		250	18	
	Malleable cast iron	Ferritic		130	19	
		Pearlitic		230	20	
N	Aluminum-wrought alloy	Not cureable		60	21	
		Cured		100	22	
	Aluminum-cast, alloyed	<=12% Si	Not cureable		75	23
			Cured		90	24
		>12% Si	High temperature		130	25
		>1% Pb	Free cutting		110	26
	Copper alloys	Brass			90	27
		Electrolytic copper			100	28
	Non-metallic	Duroplastics, fiber plastics				29
		Hard rubber				30
S	High temp. alloys	Fe based	Annealed		200	31
			Cured		280	32
		Ni or Co based	Annealed		250	33
			Cured		350	34
			Cast		320	35
	Titanium Ti alloys		RM 400		36	
			Alpha+beta alloys cured	RM 1050		37
H	Hardened steel	Hardened		55 HRC	38	
		Hardened		60 HRC	39	
	Chilled cast iron	Cast		400	40	
	Cast iron	Hardened		55 HRC	41	

• Grades: first choice IC808

(*) For workpiece materials list, see pages 1008-1043

		Feed vs. Drill Diameter F [mm/rev]										
Mat. No.	Cutting Speed Vc [m/min]		26< ØD <28		29< ØD <32		33< ØD <35		36< ØD <43		44< ØD <50	
	Vc min	Vc max	f min	f max	f min	f max	f min	f max	f min	f max	f min	f max
1	120	200	0.25	0.35	0.25	0.35	0.25	0.40	0.25	0.40	0.28	0.45
2												
3												
4	130	190	0.25	0.35	0.25	0.35	0.25	0.40	0.25	0.40	0.28	0.45
5												
6												
7	120	180	0.25	0.33	0.25	0.33	0.25	0.38	0.25	0.38	0.26	0.43
8												
9												
10	100	160	0.25	0.33	0.25	0.33	0.25	0.36	0.25	0.36	0.26	0.41
11												
12												
13	90	140	0.12	0.24	0.12	0.24	0.16	0.25	0.18	0.25	0.18	0.30
14												
15	150	250	0.25	0.40	0.25	0.45	0.3	0.50	0.3	0.50	0.35	0.55
16												
17												
18												
19												
20												
21	160	260	0.3	0.50	0.3	0.50	0.35	0.55	0.35	0.55	0.4	0.60
22												
23												
24												
25												
26												
27												
28												
29												
30												
31	30	60	0.1	0.16	0.1	0.18	0.15	0.20	0.15	0.22	0.16	0.24
32												
33												
34												
35												
36												
37												
38	20	50	0.1	0.16	0.12	0.18	0.14	0.2	0.14	0.2	0.16	0.22
39												
40												
41												

Troubleshooting



Cutting Edge Chipping

1. Check the stability of the machine spindle, tool and workpiece clamping rigidity.
2. Reduce feed rate, increase speed.
3. If the drill vibrates, reduce cutting speed and increase feed rate.
4. When drilling rough, hard or sloped surfaces (up to 7°), reduce the feed rate by 30-50% when entering and exiting.
5. Check cooling lubricant and increase coolant pressure. In case of external coolant supply, improve jet direction and add cooling jets.



Chisel Area Chipping

1. Reduce feed rate.
2. Increase coolant pressure.
3. Check the adaptation. Use hydraulic clamping chuck, MAXIN power chuck or side lock systems.
4. Increase workpiece chucking force.



Excessive Flank Wear

1. Check that the correct geometry is used.
2. Reduce cutting speed.
3. Increase internal coolant pressure.



Excessive Flute Land Wear

1. Check that the correct geometry is used.
2. Check the runout and make sure it is within 0.02 mm **T.I.R.** (radial and axial).
3. Reduce cutting speed.
4. When drilling rough, hard or sloped surfaces (up to 7°), reduce the feed rate by 30-50% when entering and exiting.
5. Increase coolant pressure.
6. Check the chisel point runout and make sure it is within 0.02 mm **T.I.R.**
7. Increase workpiece chucking force stability and rigidity.
8. If there is low pocket gripping force - replace drill body.



Built-Up Edge

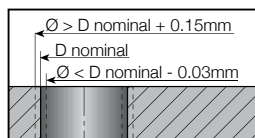

1. Increase cutting speed/feed.
2. Increase coolant pressure.



Deviation of Hole Tolerance

1. Check the runout and make sure it is within 0.02 mm **T.I.R.** (radial and axial cutting points).
2. Reduce feed rate.
3. Check the chisel point runout and make sure that it is within 0.02 mm **T.I.R.**
4. Wrong cutting edge. Replace head.
5. Increase workpiece chucking force.
6. Check the adaptation. Use hydraulic clamping chuck, MAXIN power chuck or side clamping systems.
7. Increase internal coolant pressure.

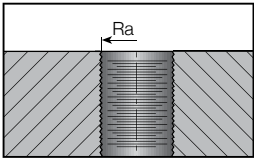
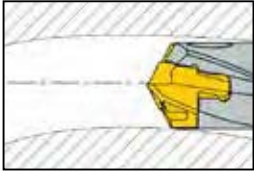
Troubleshooting

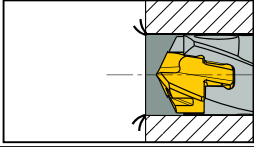
	<p>Surface Finish Too Rough</p> <ol style="list-style-type: none"> 1. Check the runout and make sure it is within 0.02 mm T.I.R. (radial and axial). 2. Adjust the feed for improved chip formation. 3. In case of chip jamming - increase the coolant flow and/or reduce the cutting speed. 4. Increase the coolant pressure. 5. Check the chisel point runout and make sure it is within 0.02 mm T.I.R. 6. Use pecking cycle. 7. Use double margin geometry.
	<p>Hole Not Straight:</p> <ul style="list-style-type: none"> • Use 2M geometry. • Drill a pre-hole for centering (check recommendations for pre-hole operation). • Increase coolant pressure; improve jet direction in case of external coolant supply. • Increase the feed.
	<p>Inaccurate Hole Position</p> <ol style="list-style-type: none"> 1. Check the runout and make sure it is within 0.02 mm T.I.R. (radial and axial). 2. Check the stability of the machine spindle, tool and workpiece clamping rigidity. 3. When drilling rough, hard or sloped surfaces (up to 7°), reduce the feed rate by 30%-50% when entering. 4. Drill a pre-hole with a 140° point angle for centering. 5. Check the chisel point runout and make sure it is within 0.02 mm T.I.R.
	<p>Burrs on Exit</p> <ol style="list-style-type: none"> 1. Reduce the feed rate by 30%-50% when exiting. 2. Replace the worn head. 3. Check the adaptation. Use hydraulic clamping chuck, maxin power chuck or side clamping systems.

Applications for DCNS Drills

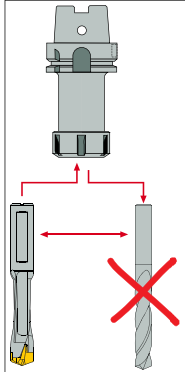
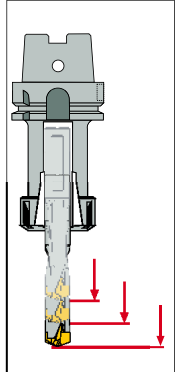
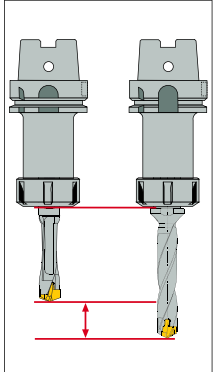
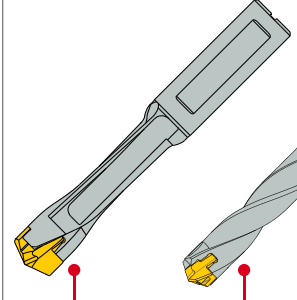
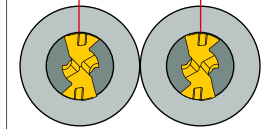
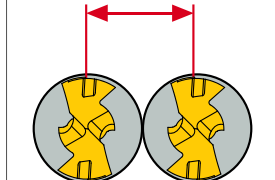
			<p>SUMO^{CHAM} CHAMDRILL LINE</p> <p>For better stability in rough applications and interrupted cuts</p>  <p>Moderate Helix High Helix</p>	<p>SUMO^{CHAM} CHAMDRILL LINE</p>  <p>SUMO^{CHAM}</p> <p>Can be used on multi-spindle applications for close spacing between adjacent drills</p> 
<p>Replaces solid carbide drills without changing any holding components</p>	<p>When using SUMOUNICHAM, the drill's projection can be adjusted</p>	<p>Shorter projection compared to SUMOCHAM, when required</p>		

Regrinding Instructions for ICM Geometry

After Each Grinding Operation Rotate the Drill 180° and Repeat the Grinding Procedure

1

Primary Clearance

2

Secondary Clearance

3

Chisel

4

T	D Range
0.05	8-11.99
0.07	12-15.99
0.08	16-19.99
0.1	20-25.99
0.12	26-32.99

$t \pm 0.02$
T-Land

Regrinding Instructions for ICP Geometry

After Each Grinding Operation Rotate the Drill 180° and Repeat the Grinding Procedure

1

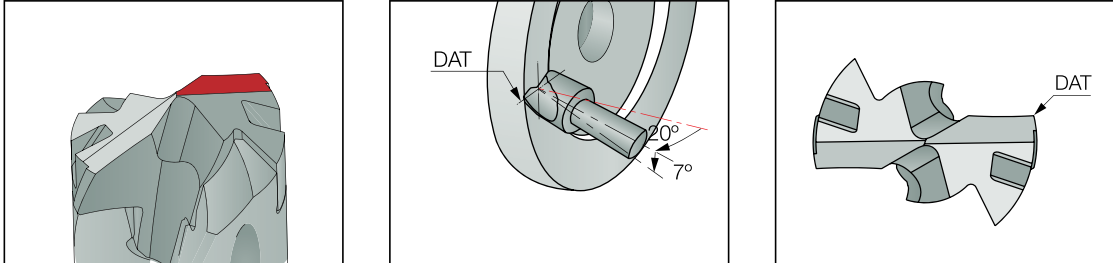

Primary Clearance

The first row illustrates the primary clearance grinding process. It consists of three panels: a 3D model of the drill tip with a red highlight on the primary clearance area; a cross-sectional view of the drill being ground against a wheel, showing a 20° angle and a 7° angle, with the datum line labeled 'DAT'; and a 3D model of the drill tip with the primary clearance area highlighted in grey.

2

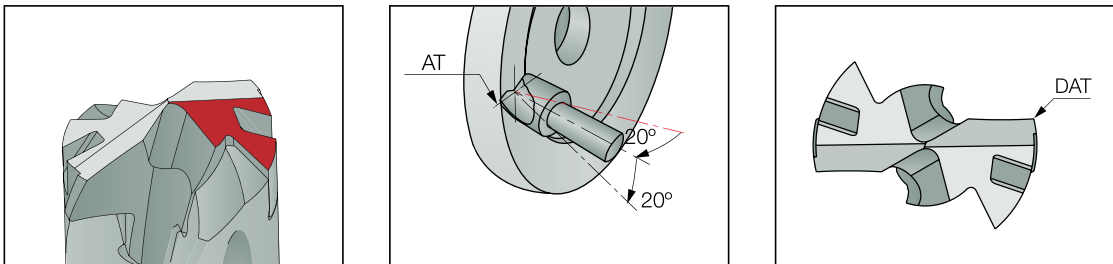

Secondary Clearance

The second row illustrates the secondary clearance grinding process. It consists of three panels: a 3D model of the drill tip with a red highlight on the secondary clearance area; a cross-sectional view of the drill being ground against a wheel, showing a 20° angle and another 20° angle, with the datum line labeled 'AT'; and a 3D model of the drill tip with the secondary clearance area highlighted in grey.

3

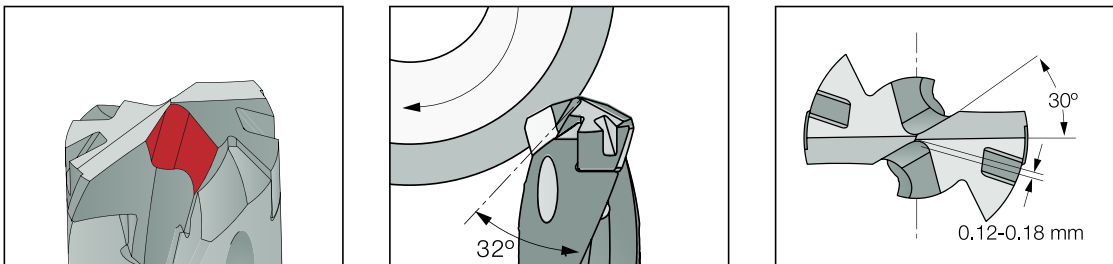

Chisel

The third row illustrates the chisel grinding process. It consists of three panels: a 3D model of the drill tip with a red highlight on the chisel edge; a cross-sectional view of the drill being ground against a wheel, showing a 32° angle; and a 3D model of the drill tip with the chisel edge highlighted in grey, showing a 30° angle and a width of 0.12-0.18 mm.

4

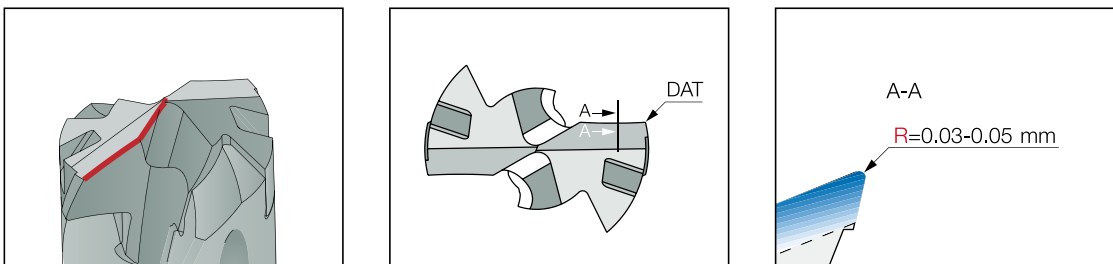

Edge Preparation

The fourth row illustrates the edge preparation process. It consists of three panels: a 3D model of the drill tip with a red highlight on the edge; a 3D model of the drill tip with the edge preparation area highlighted in grey, showing a datum line 'DAT' and a distance 'A'; and a cross-sectional view of the edge preparation, showing a radius $R=0.03-0.05$ mm and a section line 'A-A'.

Regrinding Instructions for ICK Geometry

After Each Grinding Operation Rotate the Drill 180° and Repeat the Grinding Procedure

1

Primary Clearance

2

Secondary Clearance

3

Chisel

4

Edge Preparation

DFN A-1.5D-IQ

Indexable Head Drills with Coolant Holes and One Flat Shank, Drilling Depth 1.5xD

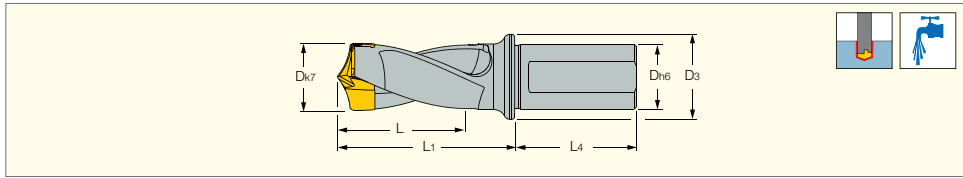

Designation	D _{min} ⁽¹⁾	D _{max}	L	d	D ₃	L ₁	L ₄	Po. Size	
DFN 330-050-32A-1.5D-IQ	33.00	33.90	50.0	32.00	42.00	87.5	60.0	33.0	K DFN 30-40
DFN 340-051-32A-1.5D-IQ	34.00	34.90	51.0	32.00	42.00	90.2	60.0	34.0	K DFN 30-40
DFN 350-053-32A-1.5D-IQ	35.00	35.90	53.0	32.00	42.00	92.8	60.0	35.0	K DFN 30-40
DFN 360-054-32A-1.5D-IQ	36.00	36.90	54.0	32.00	42.00	95.5	60.0	36.0	K DFN 30-40
DFN 370-056-32A-1.5D-IQ	37.00	37.90	56.0	32.00	42.00	98.1	60.0	37.0	K DFN 30-40
DFN 380-057-32A-1.5D-IQ	38.00	38.90	57.0	32.00	42.00	100.8	60.0	38.0	K DFN 30-40
DFN 390-059-32A-1.5D-IQ	39.00	40.00	59.0	32.00	42.00	103.4	60.0	39.0	K DFN 30-40

• For user guide and cutting conditions, see pages 507

⁽¹⁾ Do not mount smaller drilling heads other than the specified range of the drill body

For inserts, see pages: HFP-IQ (506)

DFN A-3D-IQ

Indexable Head Drills with Coolant Holes and One Flat Shank, Drilling Depth 3xD

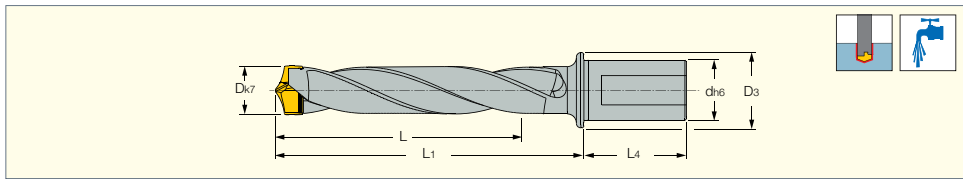

Designation	D _{min} ⁽¹⁾	D _{max}	L	d	D ₃	L ₁	L ₄	Po. Size	
DFN 330-099-32A-3D-IQ	33.00	33.90	99.0	32.00	42.00	137.0	60.0	33.0	K DFN 30-40
DFN 340-102-32A-3D-IQ	34.00	34.90	102.0	32.00	42.00	141.2	60.0	34.0	K DFN 30-40
DFN 350-105-32A-3D-IQ	35.00	35.90	105.0	32.00	42.00	145.3	60.0	35.0	K DFN 30-40
DFN 360-108-32A-3D-IQ	36.00	36.90	108.0	32.00	42.00	149.5	60.0	36.0	K DFN 30-40
DFN 370-111-32A-3D-IQ	37.00	37.90	111.0	32.00	42.00	153.6	60.0	37.0	K DFN 30-40
DFN 380-114-32A-3D-IQ	38.00	38.90	114.0	32.00	42.00	157.8	60.0	38.0	K DFN 30-40
DFN 390-117-32A-3D-IQ	39.00	40.00	117.0	32.00	42.00	161.9	60.0	39.0	K DFN 30-40

• For user guide and cutting conditions, see pages 507

⁽¹⁾ Do not mount smaller drilling heads other than the specified range of the drill body

For inserts, see pages: HFP-IQ (506)

DFN A-5D-IQ

Indexable Head Drills with Coolant Holes and One Flat Shank, Drilling Depth 5xD

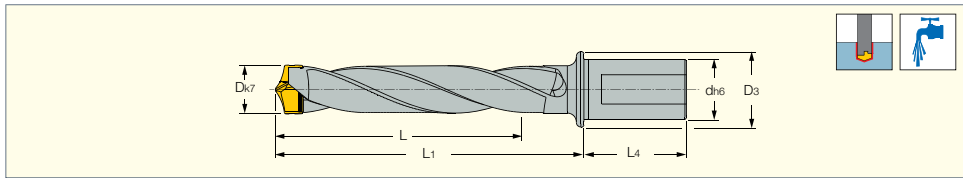

Designation	D _{min} ⁽¹⁾	D _{max}	L	d	D ₃	L ₁	L ₄	Po. Size	
DFN 330-165-32A-5D-IQ	33.00	33.90	165.0	32.00	42.00	203.0	60.0	33.0	K DFN 30-40
DFN 340-170-32A-5D-IQ	34.00	34.90	170.0	32.00	42.00	209.2	60.0	34.0	K DFN 30-40
DFN 350-175-32A-5D-IQ	35.00	35.90	175.0	32.00	42.00	215.3	60.0	35.0	K DFN 30-40
DFN 360-180-32A-5D-IQ	36.00	36.90	180.0	32.00	42.00	221.5	60.0	36.0	K DFN 30-40
DFN 370-185-32A-5D-IQ	37.00	37.90	185.0	32.00	42.00	227.6	60.0	37.0	K DFN 30-40
DFN 380-190-32A-5D-IQ	38.00	38.90	190.0	32.00	42.00	233.8	60.0	38.0	K DFN 30-40
DFN 390-195-32A-5D-IQ	39.00	40.00	195.0	32.00	42.00	239.9	60.0	39.0	K DFN 30-40

• For user guide and cutting conditions, see pages 507

⁽¹⁾ Do not mount smaller drilling heads other than the specified range of the drill body

For inserts, see pages: HFP-IQ (506)

CHAM IQ DRILL
700 LINE

DFN A-8D-IQ

Indexable Head Drills with Coolant Holes and One Flat Shank, Drilling Depth 8xD

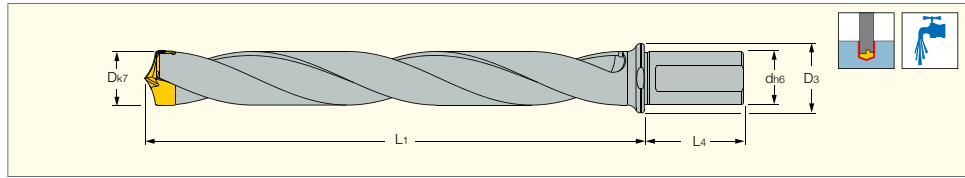

Designation	D _{min} ⁽¹⁾	D _{max}	L	d	D ₃	L ₁	L ₄	Po. Size	
DFN 330-264-32A-8D-IQ	33.00	33.90	264.0	32.00	42.00	302.0	60.0	33.0	K DFN 30-40
DFN 340-272-32A-8D-IQ	34.00	34.90	272.0	32.00	42.00	311.2	60.0	34.0	K DFN 30-40
DFN 350-280-32A-8D-IQ	35.00	35.90	280.0	32.00	42.00	320.3	60.0	35.0	K DFN 30-40
DFN 360-288-32A-8D-IQ	36.00	36.90	288.0	32.00	42.00	329.5	60.0	36.0	K DFN 30-40
DFN 370-296-32A-8D-IQ	37.00	37.90	296.0	32.00	42.00	338.6	60.0	37.0	K DFN 30-40
DFN 380-304-32A-8D-IQ	38.00	38.90	304.0	32.00	42.00	347.8	60.0	38.0	K DFN 30-40
DFN 390-312-32A-8D-IQ	39.00	40.00	312.0	32.00	42.00	356.9	60.0	39.0	K DFN 30-40

• For user guide and cutting conditions, see pages 507

⁽¹⁾ Do not mount smaller drilling heads other than the specified range of the drill body

For inserts, see pages: HFP-IQ (506)

CHAM IQ DRILL
700 LINE

HFP-IQ

Exchangeable DFN Drill Heads for Carbon and Alloy Steel (ISO P) and Cast Iron (ISO K)

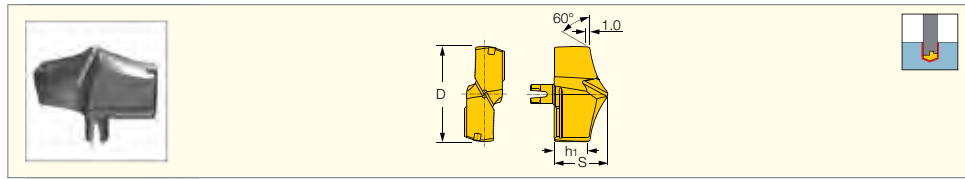

Designation	Dimensions				IC908
	D	S	h ₁	Po. Size	
HFP 330-IQ	33.00	18.50	11.2	33.0	•
HFP 333-IQ	33.30	18.50	11.2	33.0	•
HFP 335-IQ	33.50	18.50	11.2	33.0	•
HFP 339-IQ	33.90	18.50	11.2	33.0	•
HFP 340-IQ	34.00	19.70	12.1	34.0	•
HFP 343-IQ	34.30	19.70	12.1	34.0	•
HFP 345-IQ	34.50	19.70	12.1	34.0	•
HFP 350-IQ	35.00	19.70	12.1	35.0	•
HFP 355-IQ	35.50	19.70	12.1	35.0	•
HFP 360-IQ	36.00	20.80	12.7	36.0	•
HFP 365-IQ	36.50	20.80	12.7	36.0	•
HFP 370-IQ	37.00	20.80	12.8	37.0	•
HFP 375-IQ	37.50	20.80	12.8	37.0	•
HFP 380-IQ	38.00	22.00	13.8	38.0	•
HFP 385-IQ	38.50	22.00	13.8	38.0	•
HFP 390-IQ	39.00	22.00	13.6	39.0	•
HFP 395-IQ	39.50	22.00	13.6	39.0	•
HFP 400-IQ	40.00	23.00	14.4	39.0	•

• Intermediate sizes can be supplied on request

For tools, see pages: DFN A-1.5D-IQ (505) • DFN A-3D-IQ (505) • DFN A-5D-IQ (505) • DFN A-8D-IQ (506)

Insert Clamping Instructions

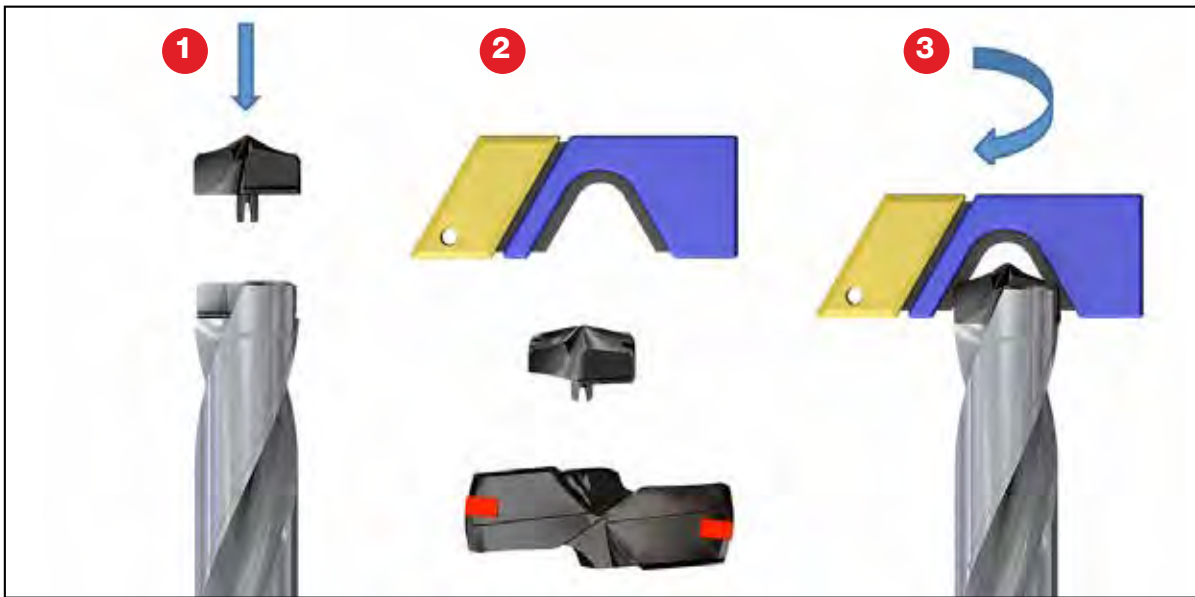

1		Exiting inclined surface Up to 7°, reduce feed by 50-70% during exiting
2		Entering inclined surface Up to 7°
3		Boring Not possible
4		Cross hole Maximum cross hole diameter must be ¼ of drill diameter
5		Stacked plates Requires a rigid clamping
6		Chamber Reduce feed by 50-70%, maximum depth 3XD
7		Convex The radius of the penetration surface must be 4X the CHAMIQDRILL head ØD. Short pre-hole is needed
8		Concave Spot facing operation is needed before drilling

Cutting Condition Recommendations

		CHAMIQDRILL	
		Feed vs. Drill Diameter	
Mtl. No.	V m/min	D=33.0-40.0	
		mm/rev	
1	80- 110 -140	0.30	0.50
2	80- 105 -130		
3	80- 100 -120		
4	70- 90 -110		
5	50- 70 -90		
6	80- 100 -120	0.30	0.50
7	70- 90 -110		
8	50- 70 -90		
9	40- 55 -70		
10	50- 70 -90		
11	40- 60 -80	0.25	0.35
15	90- 125 -160	0.40	0.60
16	80- 110 -140		
17	90- 135 -180		
18	80- 110 -140		
19	90- 125 -160		
20	80- 110 -140		

Flow Rate vs. Pressure and Drill Diameter

Drill Diameter (mm)	Pressure (bar)	Flow Rate (liter/min)
33	20	60
34	20	60
35	20	60
36	20	60
37	20	60
38	20	70
39	20	70
40	20	70

**Indication of Drill Head Wear
Wear Limit**



Diameter Change

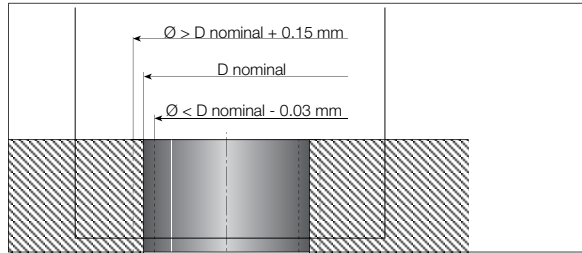

Power Restriction

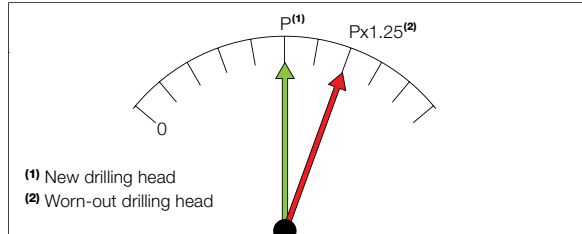

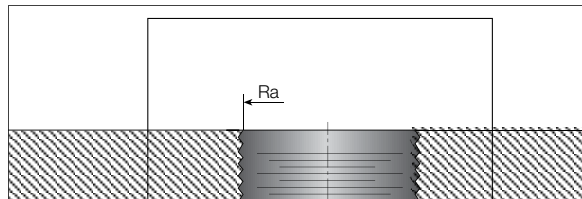

Surface Finish Declines





Achievable Hole Tolerances

5xD Drills

Alloy and Carbon Steel and Cast Iron

Hole Geometrical Feature	What Should You Expect
∅ Diameter tolerance	+0.06 mm
Circularity 	0.035
Hole axis straightness (/100mm)	0.03-0.10
Surface finish 	0.6-3.2Ra

400 mm Modular Drills Alloy and Carbon Steel and Cast Iron

Hole Geometrical Feature	What Should You Expect
∅ Diameter tolerance	+0.06 mm
Circularity 	0.035
Hole axis straightness (/100mm)	0.03-0.15
Surface finish 	0.6-3.2Ra

Troubleshooting



Cutting Edge Chipping

1. Check the stability of the machine spindle, tool and workpiece clamping rigidity.
2. Reduce feed rate, increase speed.
3. If the drill vibrates, reduce cutting speed and increase feed rate.
4. When drilling rough, hard or sloped surfaces (up to 7°), reduce the feed rate by 50-70% when entering and exiting.
5. Check cooling lubricant and increase coolant pressure. In case of external coolant supply, improve jet direction and add cooling jets.



Chisel Area Chipping

1. Reduce feed rate.
2. Increase coolant pressure.
3. Increase workpiece chucking force.



Excessive Flank Wear

1. Reduce cutting speed.
2. Increase internal coolant pressure.



Excessive Land Wear

1. Check the runout and make sure it is within 0.03 mm **T.I.R.** (radial and axial).
2. Reduce cutting speed.
3. When drilling rough, hard or sloped surfaces (up to 7°), reduce the feed rate by 50%-70% when entering and exiting.
4. Increase coolant pressure.
5. Check the chisel point runout and make sure it is within 0.03 mm **T.I.R.**
6. Increase workpiece chucking force stability and rigidity.

Troubleshooting

**Built-Up Edge**

1. Increase cutting speed/feed.
2. Increase coolant pressure.

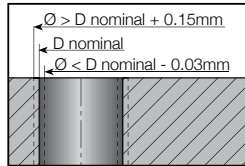
**Deviation of Hole Tolerance**

1. Check the runout and make sure it is within 0.03 mm **T.I.R.** (radial and axial cutting points).
2. Reduce feed rate.
3. Check the chisel point runout and make sure it is within 0.03 mm **T.I.R.**
4. Worn cutting edge. Replace head.
5. Increase workpiece chucking force.
6. Increase internal coolant pressure.

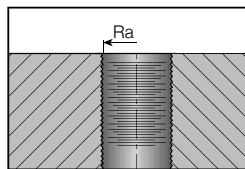
**Surface Finish Too Rough**

1. Check the runout and make sure it is within 0.03 mm **T.I.R.** (radial and axial).
2. Adjust the feed for improved chip formation.
3. In case of chip jamming - increase the coolant flow and/or reduce the cutting speed.
4. Increase the coolant pressure.
5. Check the chisel point runout and make sure it is within 0.03 mm **T.I.R.**
6. Use pecking cycle.
7. Replace the drilling head

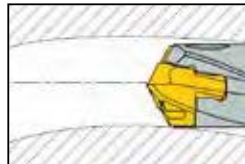
**Hole Not Straight**

- Drill a pre-hole for centering (check recommendations for pre-hole operation).
- Increase coolant pressure; improve jet direction in case of external coolant supply.
- Increase the feed.

Inaccurate Hole Position

1. Check the runout and make sure it is within 0.03 mm **T.I.R.** (radial and axial).
2. Check the stability of the machine spindle, tool and workpiece clamping rigidity.
3. When drilling rough, hard or sloped surfaces (up to 7°), reduce the feed rate by 50%-70% when entering.
4. Drill a pre-hole with a 140° point angle for centering.
5. Check the chisel point runout and make sure it is within 0.03 mm **T.I.R.**

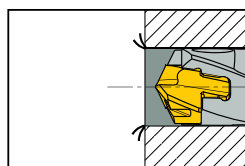
**Burrs on Exit**

1. Reduce the feed rate by 50%-70% when exiting.
2. Replace the worn head.

CHAMDRILL

DCM-3D (7.5-25.9 mm)

Indexable Head Drills with One Flat Shank, Drilling Depth 3xD

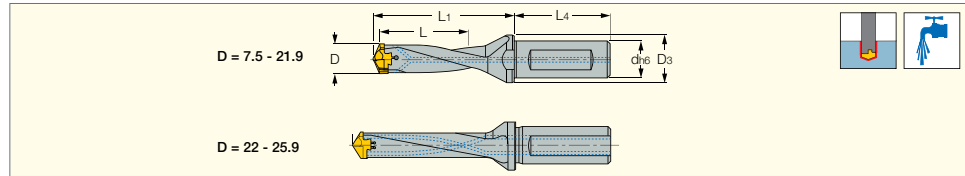

Designation	D _{min} ⁽¹⁾	D _{max}	L	d	D ₃	L ₁	L ₄	Po. Size	
DCM 075-022-12A-3D	7.50	7.90	22.0	12.00	16.00	33.1	45.0	8.0	K DCM- 8
DCM 080-024-12A-3D	8.00	8.40	24.0	12.00	16.00	35.0	45.0	8.0	K DCM- 8
DCM 085-025-12A-3D	8.50	8.90	25.0	12.00	16.00	37.0	45.0	8.0	K DCM- 8
DCM 090-027-12A-3D	9.00	9.40	27.0	12.00	16.00	39.1	45.0	9.0	K DCM- 9
DCM 095-028-12A-3D	9.50	9.90	28.0	12.00	16.00	41.1	45.0	9.0	K DCM- 9
DCM 100-030-16A-3D	10.00	10.40	30.0	16.00	20.00	44.0	48.0	10.0	K DCM-10
DCM 105-031-16A-3D	10.50	10.90	31.0	16.00	20.00	46.0	48.0	10.0	K DCM-10
DCM 110-033-16A-3D	11.00	11.40	33.0	16.00	20.00	48.1	48.0	11.0	K DCM-11
DCM 115-034-16A-3D	11.50	11.90	34.0	16.00	20.00	50.0	48.0	11.0	K DCM-11
DCM 120-036-16A-3D	12.00	12.40	36.0	16.00	20.00	52.2	48.0	12.0	K DCM-12
DCM 125-037-16A-3D	12.50	12.90	37.0	16.00	20.00	53.8	48.0	12.0	K DCM-12
DCM 130-039-16A-3D	13.00	13.40	39.0	16.00	20.00	56.5	48.0	13.0	K DCM-13
DCM 135-040-16A-3D	13.50	13.90	40.0	16.00	20.00	58.5	48.0	13.0	K DCM-13
DCM 140-042-16A-3D	14.00	14.40	42.0	16.00	20.00	61.2	48.0	14.0	K DCM-14
DCM 145-043-16A-3D	14.50	14.90	43.0	16.00	20.00	64.8	48.0	14.0	K DCM-14
DCM 150-045-20A-3D	15.00	15.90	45.0	20.00	25.00	65.7	50.0	15.0	K DCM-15
DCM 160-048-20A-3D	16.00	16.90	48.0	20.00	25.00	70.0	50.0	16.0	K DCM-16
DCM 170-051-20A-3D	17.00	17.90	51.0	20.00	25.00	73.5	50.0	17.0	K DCM-17
DCM 180-054-25A-3D	18.00	18.90	54.0	25.00	32.00	78.3	56.0	18.0	K DCM-18
DCM 190-057-25A-3D	19.00	19.90	57.0	25.00	32.00	82.3	56.0	19.0	K DCM-19
DCM 200-060-25A-3D	20.00	20.90	60.0	25.00	32.00	87.0	56.0	20.0	K DCM-20
DCM 210-063-25A-3D	21.00	21.90	63.0	25.00	32.00	90.8	56.0	21.0	K DCM-21
DCM 220-066-25A-3D	22.00	22.90	66.0	25.00	32.00	95.1	56.0	22.0	K DCM-22
DCM 230-069-25A-3D	23.00	23.90	69.0	25.00	32.00	99.5	56.0	23.0	K DCM-23
DCM 240-072-25A-3D	24.00	24.90	72.0	25.00	32.00	103.6	56.0	24.0	K DCM-24
DCM 250-075-25A-3D	25.00	25.90	75.0	25.00	32.00	109.0	56.0	25.0	K DCM-25

• Drill tolerance: k7 • For user guide and cutting conditions, see page 514

⁽¹⁾ Do not mount smaller drilling heads other than the specified range of the drill body

For inserts, see pages: IDI-SG (513) • IDI-SK (513)

UNICHAMDRILL

DCM-3.5D (7.5-20.9 mm)

Indexable Head Drills without a Flange and One Flat Shank, Drilling Depth 3.5xD, Suitable for Chamfering Holders

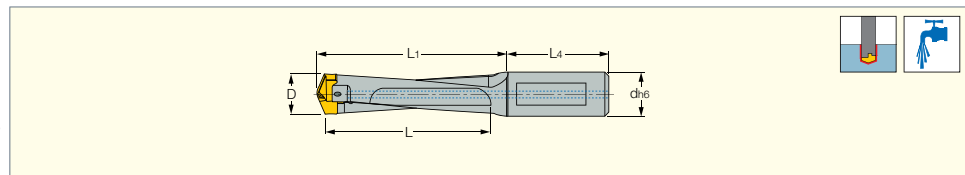

Designation	D _{min} ⁽¹⁾	D _{max}	L	d	L ₁	L ₄	Po. Size	
DCM 075-026-8B-3.5D	7.50	7.90	26.0	8.00	33.7	43.0	8.0	K DCM- 8
DCM 080-028-8B-3.5D	8.00	8.40	28.0	8.00	35.9	43.0	8.0	K DCM- 8
DCM 085-029-9B-3.5D	8.50	8.90	29.0	9.00	36.9	43.0	8.0	K DCM- 8
DCM 090-031-9B-3.5D	9.00	9.40	31.0	9.00	39.1	43.0	9.0	K DCM- 9
DCM 095-033-10B-3.5D	9.50	9.90	33.0	10.00	40.3	43.0	9.0	K DCM- 9
DCM 100-033-10B-3.5D	10.00	10.40	33.0	10.00	43.0	43.0	10.0	K DCM-10
DCM 105-034-11B-3.5D	10.50	10.90	34.0	11.00	44.8	43.0	10.0	K DCM-10
DCM 110-036-11B-3.5D	11.00	11.40	36.0	11.00	46.9	43.0	11.0	K DCM-11
DCM 115-038-12B-3.5D	11.50	11.90	38.0	12.00	48.6	43.0	11.0	K DCM-11
DCM 120-042-12B-3.5D	12.00	12.40	42.0	12.00	50.8	43.0	12.0	K DCM-12
DCM 125-042-13B-3.5D	12.50	12.90	42.0	13.00	52.6	43.0	12.0	K DCM-12
DCM 130-042-13B-3.5D	13.00	13.40	42.0	13.00	54.5	45.0	13.0	K DCM-13
DCM 135-044-14B-3.5D	13.50	13.90	44.0	14.00	56.2	45.0	13.0	K DCM-13
DCM 140-048-14B-3.5D	14.00	14.40	48.0	14.00	59.2	45.0	14.0	K DCM-14
DCM 145-050-15B-3.5D	14.50	14.90	50.0	15.00	60.9	45.0	14.0	K DCM-14
DCM 150-052-15B-3.5D	15.00	15.90	52.0	15.00	63.1	45.0	15.0	K DCM-15
DCM 160-052-16B-3.5D	16.00	16.90	52.0	16.00	67.0	48.0	16.0	K DCM-16
DCM 170-055-17B-3.5D	17.00	17.90	55.0	17.00	73.6	48.0	17.0	K DCM-17
DCM 180-060-18B-3.5D	18.00	18.90	60.0	18.00	78.3	48.0	18.0	K DCM-18
DCM 190-062-19B-3.5D	19.00	19.90	62.5	19.00	81.8	54.0	19.0	K DCM-19
DCM 200-066-20B-3.5D	20.00	20.90	66.0	20.00	84.6	54.0	20.0	K DCM-20

• Drill tolerance: k7 • For user guide and cutting conditions, see pages 514, 518

⁽¹⁾ Do not mount smaller drilling heads other than the specified range of the drill body

For inserts, see pages: IDI-SG (513) • IDI-SK (513)

CHAMDRILL

DCM-5D (7.5-25.9 mm)

Indexable Head Drills with One Flat Shank, Drilling Depth 5xD

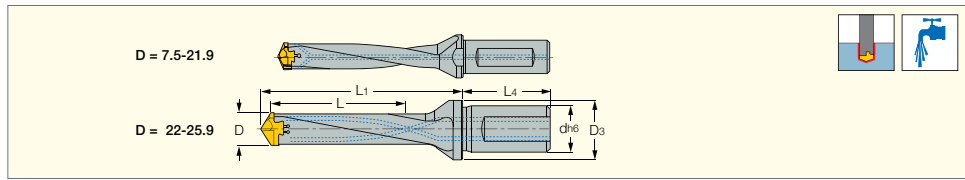

Designation	D _{min} ⁽¹⁾	D _{max}	L	d	D ₃	L ₁	L ₄	Po. Size	
DCM 075-037-12A-5D	7.50	7.90	37.0	12.00	16.00	48.1	45.0	8.0	K DCM- 8
DCM 080-040-12A-5D	8.00	8.40	40.0	12.00	16.00	51.0	45.0	8.0	K DCM- 8
DCM 085-042-12A-5D	8.50	8.90	42.0	12.00	16.00	54.0	45.0	8.0	K DCM- 8
DCM 090-045-12A-5D	9.00	9.40	45.0	12.00	16.00	57.1	45.0	9.0	K DCM- 9
DCM 095-047-12A-5D	9.50	9.90	47.0	12.00	16.00	60.1	45.0	9.0	K DCM- 9
DCM 100-050-16A-5D	10.00	10.40	50.0	16.00	20.00	64.0	48.0	10.0	K DCM-10
DCM 105-052-16A-5D	10.50	10.90	52.0	16.00	20.00	67.0	48.0	10.0	K DCM-10
DCM 110-055-16A-5D	11.00	11.40	55.0	16.00	20.00	70.1	48.0	11.0	K DCM-11
DCM 115-057-16A-5D	11.50	11.90	57.0	16.00	20.00	73.0	48.0	11.0	K DCM-11
DCM 120-060-16A-5D	12.00	12.40	60.0	16.00	20.00	76.2	48.0	12.0	K DCM-12
DCM 125-062-16A-5D	12.50	12.90	62.0	16.00	20.00	79.2	48.0	12.0	K DCM-12
DCM 130-065-16A-5D	13.00	13.40	65.0	16.00	20.00	82.5	48.0	13.0	K DCM-13
DCM 135-067-16A-5D	13.50	13.90	67.0	16.00	20.00	85.5	48.0	13.0	K DCM-13
DCM 140-070-16A-5D	14.00	14.40	70.0	16.00	20.00	89.2	48.0	14.0	K DCM-14
DCM 145-072-16A-5D	14.50	14.90	72.0	16.00	20.00	92.2	48.0	14.0	K DCM-14
DCM 150-075-20A-5D	15.00	15.90	75.0	20.00	25.00	95.7	50.0	15.0	K DCM-15
DCM 160-080-20A-5D	16.00	16.90	80.0	20.00	25.00	102.0	50.0	16.0	K DCM-16
DCM 170-085-20A-5D	17.00	17.90	85.0	20.00	25.00	107.5	50.0	17.0	K DCM-17
DCM 180-090-25A-5D	18.00	18.90	90.0	25.00	32.00	114.3	56.0	18.0	K DCM-18
DCM 190-095-25A-5D	19.00	19.90	95.0	25.00	32.00	120.3	56.0	19.0	K DCM-19
DCM 200-100-25A-5D	20.00	20.90	100.0	25.00	32.00	127.0	56.0	20.0	K DCM-20
DCM 210-105-25A-5D	21.00	21.90	105.0	25.00	32.00	132.8	56.0	21.0	K DCM-21
DCM 220-110-25A-5D	22.00	22.90	110.0	25.00	32.00	139.1	56.0	22.0	K DCM-22
DCM 230-115-25A-5D	23.00	23.90	115.0	25.00	32.00	145.5	56.0	23.0	K DCM-23
DCM 240-120-25A-5D	24.00	24.90	120.0	25.00	32.00	151.6	56.0	24.0	K DCM-24
DCM 250-125-25A-5D	25.00	25.90	125.0	25.00	32.00	159.0	56.0	25.0	K DCM-25

• Drill tolerance: k7 • For user guide and cutting conditions, see page 514

⁽¹⁾ Do not mount smaller drilling heads other than the specified range of the drill body

For inserts, see pages: IDI-SG (513) • IDI-SK (513)

CHAMDRILL

DCM-8D (10-25.9 mm)

Indexable Head Drills with One Flat Shank, Drilling Depth 8xD

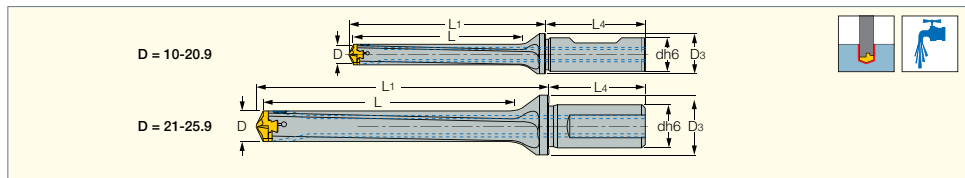

Designation	D _{min} ⁽¹⁾	D _{max}	L	d	D ₃	L ₁	L ₄	Po. Size	
DCM 100-080-16A-8D	10.00	10.90	80.0	16.00	20.00	94.0	48.0	10.0	K DCM-10
DCM 110-088-16A-8D	11.00	11.90	88.0	16.00	20.00	103.2	48.0	11.0	K DCM-11
DCM 120-096-16A-8D	12.00	12.90	96.0	16.00	20.00	112.3	48.0	12.0	K DCM-12
DCM 130-104-16A-8D	13.00	13.90	104.0	16.00	20.00	121.5	48.0	13.0	K DCM-13
DCM 140-112-16A-8D	14.00	14.90	112.0	16.00	20.00	131.2	48.0	14.0	K DCM-14
DCM 150-120-20A-8D	15.00	15.90	120.0	20.00	25.00	140.7	50.0	15.0	K DCM-15
DCM 160-128-20A-8D	16.00	16.90	128.0	20.00	25.00	150.0	50.0	16.0	K DCM-16
DCM 170-136-20A-8D	17.00	17.90	136.0	20.00	25.00	158.5	50.0	17.0	K DCM-17
DCM 180-144-25A-8D	18.00	18.90	144.0	25.00	32.00	168.3	56.0	18.0	K DCM-18
DCM 190-152-25A-8D	19.00	19.90	152.0	25.00	32.00	177.3	56.0	19.0	K DCM-19
DCM 200-160-25A-8D	20.00	20.90	160.0	25.00	32.00	187.2	56.0	20.0	K DCM-20
DCM 210-168-25A-8D	21.00	21.90	168.0	25.00	32.00	196.2	56.0	21.0	K DCM-21
DCM 220-176-25A-8D	22.00	22.90	176.0	25.00	32.00	205.2	56.0	22.0	K DCM-22
DCM 230-184-25A-8D	23.00	23.90	184.0	25.00	32.00	215.1	56.0	23.0	K DCM-23
DCM 240-192-25A-8D	24.00	24.90	192.0	25.00	32.00	224.5	56.0	24.0	K DCM-24
DCM 250-200-25A-8D	25.00	25.90	200.0	25.00	32.00	233.7	56.0	25.0	K DCM-25

• Drill tolerance: k7 • For user guide and cutting conditions, see page 514

⁽¹⁾ Do not mount smaller drilling heads other than the specified range of the drill body

For inserts, see pages: IDI-SG (513) • IDI-SK (513)

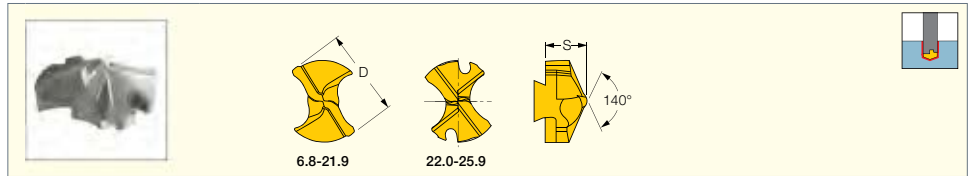

Designation	Dimensions			IC908
	D Range ⁽¹⁾	S	Pocket Size	
IDI-SG... IDI-SK...	6.8	4.1	6.8	•
	7.5-7.9	4.1	8.0	•
	8.0-8.9	4.1	8.0	•
	9.0-9.9	4.3	9.0	•
	10-10.9	5.3	10.0	•
	11-11.9	5.5	11.0	•
	12-12.9	5.8	12.0	•
	13-13.9	6.0	13.0	•
	14-14.9	6.8	14.0	•
	15-15.9	7.4	15.0	•
	16-16.9	7.9	16.0	•
	17-17.9	7.4	17.0	•
	18-18.9	8.3	18.0	•
	19-19.9	8.5	19.0	•
	20-20.9	9.3	20.0	•
	21-21.9	9.5	21.0	•
22-22.9	10.3	22.0	•	
23-23.9	10.4	23.0	•	
24-24.9	10.8	24.0	•	
25-25.9	11.0	25.0	•	

⁽¹⁾ The drilling bits are available in increments of 0.1 mm
 Ordering example for the IDI 10.0 mm drilling head: IDI 100-SG IC908

For tools, see pages: DCM (511-512)



Drilling Head Mounting Procedure

CHAMDRILL DCM Drilling Head

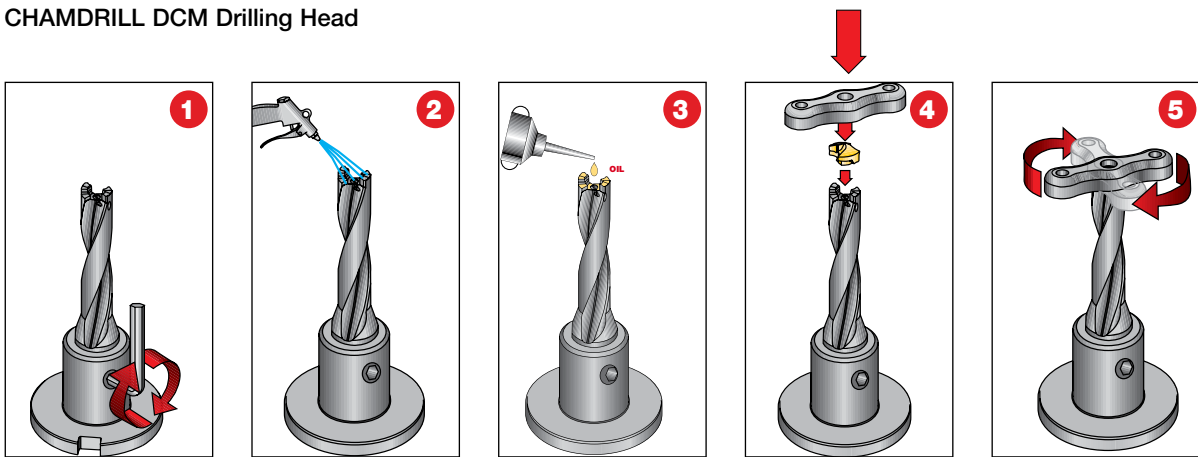

CHAMDRILL Unlocking Change in Torque
Typical Unlocking Torque Range

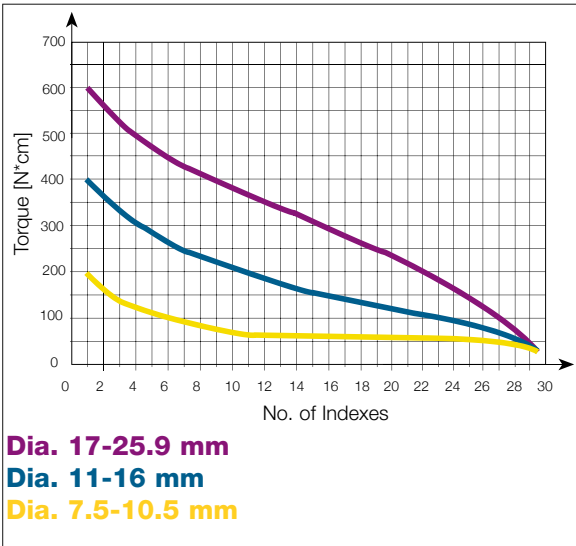

The number of indexing changes according to machine/clamping rigidity, machining conditions, workpiece material, coolant, cooling pressure and correct usage.

Coolant

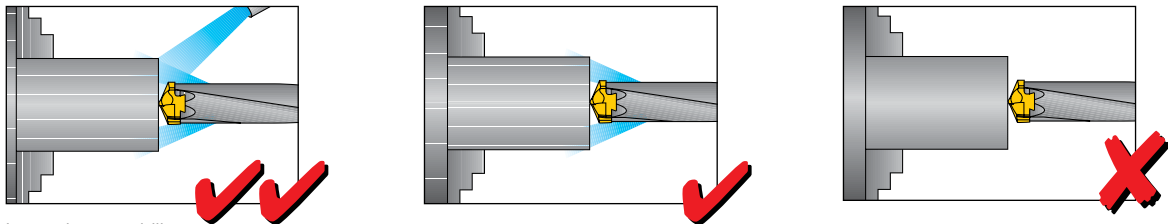

In stationary drill applications both internal and external coolant supply is recommended.

Recommended Coolant Pressure and Flow Rate

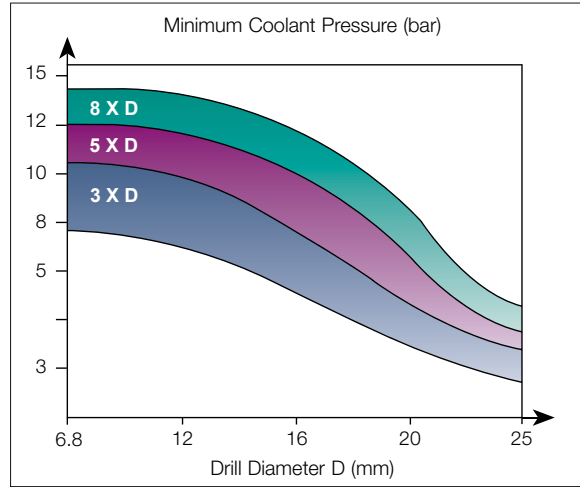
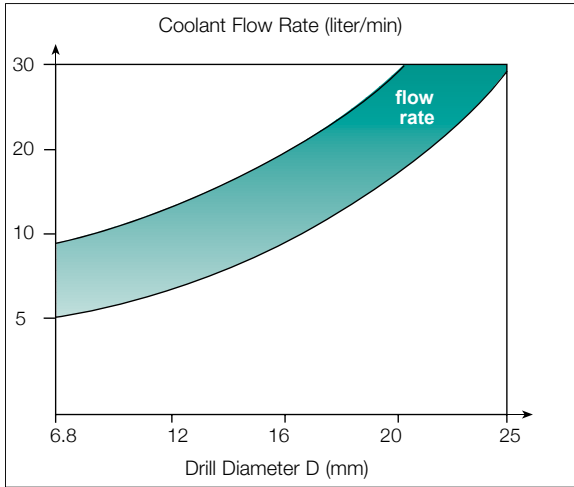

* For special drills more than 8xD, it is recommended to use higher coolant pressure: 15-70 bar.

To guarantee chip evacuation, the coolant must always flow through the tool. If the machine is not equipped with coolant through the spindle, we recommend using a coolant inducer. External coolant supply can

be used if hole depth is less than 1xD and reduced cutting data is applied. The diagram shows the coolant flow rates for different drills and pressures.

Coolant Mix

Recommended emulsion mix is 6-8%.

When drilling in stainless and high strength steels, a mix of 10% is recommended.

When using the IDI drilling head, high pressure oil or 7-15% mineral or vegetable based oil emulsion is highly recommended for drilling stainless steel and high temperature alloys.

Dry Drilling

It is possible to drill without coolant in cast iron. Oil mist through the drill is then required (for 2xD max).

Drilling Limitations

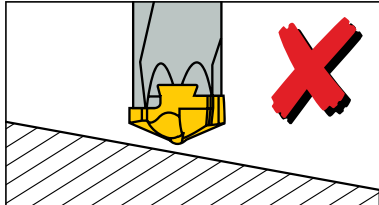

Regrinding of drill head is not recommended; it may cause drill malfunction.

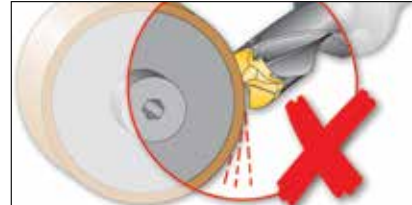
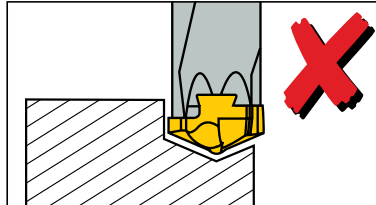

Power/Force Requirements

Power/Force Requirements

Centering Hole Data for DCM 8xD

We strongly recommend the use of DCN 1.5D drill of the same diameter to drill a centering pre-hole. The use of the centering pre-hole improves hole location, accuracy, roundness, straightness and surface finish and reliability.

Use internal coolant with at least 15 bar pressure.

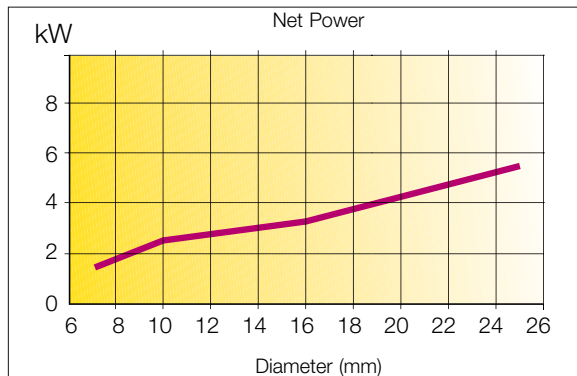
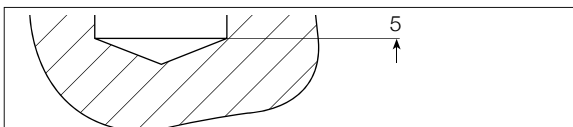

Material: SAE 4340

Speed: 100 m/min

Feed: 0.2 mm/rev

Values change for different materials and drilling conditions.

Material Groups

ISO	Material	Condition	Tensile Strength [N/mm ²]	Hardness HB	Material No.	
P	Non-alloy steel and cast steel, free cutting steel	< 0.25 %C	Annealed	420	125	1
		>= 0.25 %C	Annealed	650	190	2
		< 0.55 %C	Quenched and tempered	850	250	3
		>= 0.55 %C	Annealed	750	220	4
			Quenched and tempered	1000	300	5
	Low alloy steel and cast steel (less than 5% of alloying elements)		Annealed	600	200	6
			Quenched and tempered	930	275	7
				1000	300	8
				1200	350	9
	High alloyed steel, cast steel, and tool steel		Annealed	680	200	10
			Quenched and tempered	1100	325	11
	Stainless steel and cast steel		Ferritic/martensitic	680	200	12
			Martensitic	820	240	13
M	Stainless steel	Austenitic	600	180	14	
K	Grey cast iron (GG)	Ferritic/pearlitic		180	15	
		Pearlitic		260	16	
	Nodular cast iron (GGG)	Ferritic		160	17	
		Pearlitic		250	18	
	Malleable cast iron	Ferritic		130	19	
		Pearlitic		230	20	
N	Aluminum-wrought alloy	Not cureable		60	21	
		Cured		100	22	
	Aluminum-cast, alloyed	<=12% Si	Not cureable		75	23
			Cured		90	24
		>12% Si	High temperature		130	25
	Copper alloys	>1% Pb	Free cutting		110	26
			Brass		90	27
			Electrolitic copper		100	28
	Non-metallic		Duroplastics, fiber plastics			29
			Hard rubber			30
S	High temp. alloys	Fe based	Annealed		200	31
			Cured		280	32
		Ni or Co based	Annealed		250	33
			Cured		350	34
			Cast		320	35
	Titanium Ti alloys			RM 400		36
			Alpha+beta alloys cured		RM 1050	
H	Hardened steel	Hardened		55 HRC	38	
		Hardened		60 HRC	39	
	Chilled cast iron	Cast		400	40	
	Cast iron	Hardened		55 HRC	41	

- When using external coolant supply only, reduce cutting speed by 10%
- When using more than 5XD drill ratio, reduce cutting parameters by 10%

Recommended Machining Conditions

Mat.No.	Cutting Speed Vc m/min	Feed vs. Drill Diameter mm/rev						
		D=6.8-10.9	D=11-12.9	D=13-14.9	D=15-16.9	D=17-20.9	D=21-25.9	
1	50-130	0.12-0.2	0.15-0.25	0.2-0.3	0.25-0.35	0.25-0.45	0.25-0.45	
2	100-120							
3	90-110							
4	90-120							
5	70-90							
6	80-130	0.12-0.2	0.15-0.25	0.2-0.3	0.25-0.35	0.3-0.4	0.3-0.45	
7	70-110							
8	60-90							
9	40-70							
10	50-80	0.12-0.2	0.12-0.22	0.15-0.25	0.2-0.28	0.25-0.33	0.25-0.35	
11	40-70							
12	20-50	0.08-0.14	0.12-0.22	0.12-0.15	0.14-0.20	0.16-0.24	0.15-0.28	
13								
14	20-50	0.08-0.14	0.12-0.22	0.12-0.15	0.14-0.20	0.16-0.24	0.15-0.28	
15	90-140	0.2-0.3	0.25-0.35	0.3-0.4	0.35-0.45	0.4-0.5	0.4-0.6	
16	80-130							
17	100-180							
18	90-160							
19								
20								
21	90-160	0.2-0.35	0.25-0.4	0.3-0.45	0.35-0.5	0.4-0.6	0.4-0.65	
22								
23								
24								
25								80-120
26								
27								
28								
29								
30								
31	30-50	0.05-0.1	0.08-0.13	0.1-0.15	0.12-0.18	0.12-0.2	0.12-0.22	
32								
33								
34								
35								
36	20-50	0.06-0.12	0.09-0.15	0.12-0.18	0.15-0.2	0.15-0.23	0.15-0.25	
37								
38	20-50	0.06-0.12	0.09-0.15	0.12-0.18	0.15-0.2	0.15-0.23	0.15-0.25	
39								
40								
41								

As a starting value, the middle of the recommended machining range should be used.
 Then, according to the wear results, conditions can be changed to optimize performance.
 The data refers to IC908. For IC1008, cutting speed should be increased by 15%.

Applications for DCM 3.5D

			<p>UNICHAMDRILL CHAMDRILL</p> <p>For better stability in rough applications and interrupted cuts</p> <p>Moderate Helix High Helix</p>	<p>CHAMDRILL</p> <p>UNICHAMDRILL</p> <p>Can be used on multi-spindle applications for close spacing between adjacent drills</p>
<p>Replaces solid carbide drills without changing any holding components</p>	<p>When using UNICHAMDRILL, the drill's projection can be adjusted</p>	<p>Shorter projection compared to CHAMDRILL when required</p>		

Troubleshooting

	<p>Cutting Edge Chipping</p> <ol style="list-style-type: none"> 1. Check the stability of the machine spindle, tool and workpiece clamping rigidity. 2. Reduce feed rate, increase speed. 3. If the drill vibrates, reduce cutting speed and increase feed rate. 4. When drilling rough, hard or sloped surfaces (up to 6°), reduce the feed rate by 30-50% when entering and exiting. 5. Check cooling lubricant and increase coolant pressure. In case of external coolant supply, improve jet direction and add cooling jets.
	<p>Excessive Flank Wear</p> <ol style="list-style-type: none"> 1. Check that the correct geometry is used. 2. Reduce cutting speed. 3. Increase internal coolant pressure.
	<p>Chisel Area Chipping</p> <ol style="list-style-type: none"> 1. Reduce feed rate. 2. Increase coolant pressure. 3. Check the adaptation. Use hydraulic clamping chuck, MAXIN power chuck or side lock systems. 4. Increase workpiece chucking force.
	<p>Excessive Flute Land Wear</p> <ol style="list-style-type: none"> 1. Check that the correct geometry is used. 2. Check the runout and make sure it is within 0.02 mm T.I.R. (radial and axial). 3. Reduce cutting speed. 4. When drilling rough, hard or sloped surfaces (up to 6°), reduce the feed rate by 30-50% when entering and exiting. 5. Increase coolant pressure. 6. Check the chisel point runout and make sure it is within 0.02 mm T.I.R. 7. Increase workpiece chucking force stability and rigidity. 8. If there is low pocket gripping force - replace drill body.

Troubleshooting



Built-Up Edge

1. Increase cutting speed.
2. Increase coolant pressure.

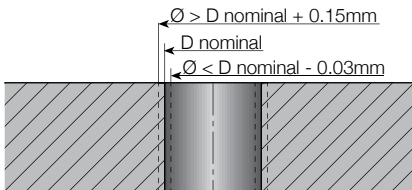

Deviation of Hole Tolerance

1. Check the runout and make sure it is within 0.02 mm **T.I.R.** (radial and axial cutting points).
2. Reduce feed rate.
3. Check the chisel point runout and make sure that it is within 0.02 mm **T.I.R.**
4. Wrong cutting edge. Replace head.
5. Increase workpiece chucking force.
6. Check the adaptation. Use hydraulic clamping chuck, MAXIN power chuck or side clamping systems.
7. Increase internal coolant pressure.

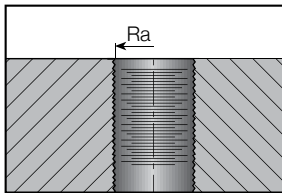

Surface Finish Too Rough

1. Check the runout and make sure it is within 0.02 mm **T.I.R.** (radial and axial).
2. Adjust the feed for improved chip formation.
3. In case of chip jamming - increase the coolant flow and/or reduce the cutting speed.
4. Increase the coolant pressure.
5. Check the chisel point runout and make sure it is within 0.02 mm **T.I.R.**
6. Use pecking cycle.



Insufficient Pocket Gripping Torque

1. Check unlocking gripping torque with **TK DCM** torque key. If there is no click indication - replace drill head.
2. Increase coolant pressure.

Inaccurate Hole Position

1. Check the runout and make sure it is within 0.02 mm **T.I.R.** (radial and axial).
2. Check the stability of the machine spindle, tool and workpiece clamping rigidity.
3. When drilling rough, hard or sloped surfaces (up to 6°), reduce the feed rate by 30-50% when entering.
4. Drill a pre-hole with a 140° point angle for centering.
5. Check the chisel point runout and make sure it is within 0.02 mm **T.I.R.**

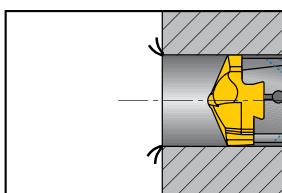

Burrs on Exit

1. Reduce the feed rate by 30-50% when exiting.
2. Replace the worn head.
3. Check the adaptation. Use hydraulic clamping chuck, MAXIN power chuck or side clamping systems.